

# Notice

---

## Hewlett-Packard to Agilent Technologies Transition

This manual may contain references to HP or Hewlett-Packard. Please note that Hewlett-Packard's former test and measurement, semiconductor products and chemical analysis businesses are now part of Agilent Technologies. To reduce potential confusion, the only change to product numbers and names has been in the company name prefix: where a product name/number was HP XXXX the current name/number is now Agilent XXXX. For example, model number HP 8648 is now model number Agilent 8648.

## Contacting Agilent Sales and Service Offices

The sales and service contact information in this manual may be out of date. The latest service and contact information for your location can be found on the Web at:

<http://www.agilent.com/find/assist>

If you do not have access to the Internet, contact your field engineer. In any correspondence or telephone conversation, refer to your instrument by its model number and full serial number.



# Calibration Guide

## HP ESG Series Signal Generators

### Serial Number Prefixes:

HP ESG-1000A, US3704 through US3723  
HP ESG-2000A, US3704 through US3723  
HP ESG-3000A, US3704 through US3723  
HP ESG-4000A, US3704 through US3723



**HP Part No. E4400-90079**

**Printed in USA**

**Print Date: October 1997 Supersedes: June 1997**

©Copyright Hewlett-Packard Company 1997. All Rights Reserved. Reproduction, adaptation, or translation without prior written permission is prohibited, except as allowed under the copyright laws.

1400 Fountaingrove Parkway, Santa Rosa, CA 95403-1799, USA



---

## Contents

### 1 Specifications

HP ESG Series Signal Generators Specifications ..... 1-2

### 2 Equipment Required

Required Equipment ..... 2-2

### 3 Operation Verification

Verification Procedures..... 3-2

### 4 Service Software

Required Test Equipment ..... 4-2

Installing the ESG Series Support Software ..... 4-3

ESG Series Support Software Administration..... 4-4

### 5 Performance Tests

Calibration Cycle ..... 5-2

Performance Test Records ..... 5-3

Recommended Test Equipment ..... 5-4

Support Software ..... 5-5

1. Internal FM Accuracy and Distortion Performance Tests ..... 5-11

2. Internal AM Accuracy and Distortion Performance Tests ..... 5-12

---

## Contents

3. Phase Modulation Accuracy and Distortion Performance Tests ....	5-16
4. FM Frequency Response Performance Test .....	5-17
5. AM Frequency Response Performance Test .....	5-18
6. Phase Modulation Frequency Response Performance Test.....	5-20
7. DCFM Frequency Offset Relative to CW Performance Test .....	5-21
8. Residual FM Performance Test .....	5-22
9. Harmonic, Subharmonic, and Nonharmonic Spurious Signals Performance Tests .....	5-25
10. Power Level Accuracy Performance Test .....	5-26
11. Timebase Aging Rate Performance Test: Option 1E5 ONLY .....	5-30
12. Pulse Modulation On/Off Ratio Performance Test .....	5-33
13. Modulation Source Frequency Accuracy Performance Test .....	5-34
Performance Test Records .....	5-35
<b>6 Adjustments</b>	
Adjustment Relationships.....	6-2
Internal Reference Oscillator Adjustment .....	6-4
Analog Bus ADC Calibration.....	6-6
Internal Source Calibration .....	6-7
VCO Bias Potentiometer Adjustment .....	6-8
Lock Angle Potentiometer Adjustment .....	6-9

---

## Contents

KV versus Frequency Calibration .....	6-10
AM Audio Path Offset Calibration.....	6-11
Timebase DAC Calibration .....	6-12
FM Scale DAC Offset Calibration .....	6-13
FM Path Offset Calibration .....	6-14
FM In-Band DAC Offset Calibration .....	6-15
FM Inverting Amplifier Offset Calibration .....	6-16
FM 1/2 Path Ratio Gain Calibration.....	6-17
Modulation Source Relative Gain Compression Calibration .....	6-18
FM Out-Of-Band Calibration .....	6-19
FM Delay Potentiometer Adjustment.....	6-20
Wide Bandwidth Phase Modulation Calibration .....	6-21
DCFM Calibration.....	6-22
Low Frequency (LF) Output Calibration.....	6-23
External Input Peak Detector Calibration.....	6-24
Burst Modulator Calibration.....	6-25
Burst Audio Path Gain Calibration.....	6-27
Prelevel Calibration .....	6-28
Gain Adjust Calibration.....	6-29
ALC Modulation Driver Bias Calibration .....	6-30

---

## Contents

VBLO Mixer Bias Calibration .....	6-31
Automatic Leveling Control (ALC) Calibration .....	6-32
Power Flatness Calibration.....	6-33
Attenuator Calibration (Power Meter) .....	6-34
Level Meter Calibration .....	6-35
ALC Modulation Flatness Calibration .....	6-36
AM Gain Calibration.....	6-37
Low Level Step Attenuator Calibration .....	6-38
<b>7 Maintenance and Service</b>	
Preventive Maintenance Procedures .....	7-2
Returning Your Signal Generator to HP.....	7-3
HP Sales and Service Offices.....	7-4
<b>8 Safety and Regulatory</b>	
Safety Notes .....	8-2
Instrument Markings .....	8-3
General Safety Considerations .....	8-4
Statement of Compliance .....	8-5
Electrostatic Discharge.....	8-6

---

## Contents

Warranty .....	8-7
Assistance .....	8-8
Certification .....	8-9

## Index



---

## Contents

---

# 1 Specifications

---

This chapter lists the specifications and supplemental characteristics for the HP ESG Series Signal Generators whose serial prefixes are listed on the title page.

---

## HP ESG Series Signal Generators Specifications

Specifications describe the instrument's warranted performance and apply after a 45 minute warm-up. All specifications are valid over the signal generator's entire operating and environmental range while in phase noise mode 2, unless otherwise noted.

Supplemental characteristics (shown in italics and denoted typical or nominal) provide additional, non-warranted, information useful in applying the signal generator.

### Frequency

**Range:**

**HP ESG-1000A:** 250 kHz to 1000 MHz

**HP ESG-2000A:** 250 kHz to 2000 MHz

**HP ESG-3000A:** 250 kHz to 3000 MHz

**HP ESG-4000A:** 250 kHz to 4000 MHz

**Underrange:** 100 kHz

**Resolution:** 0.01 Hz

**Accuracy:** Same as timebase

**Switching Speed<sup>1</sup>:**

**Modulation On:** < 45 ms, typical

**Modulation Off:** < 35 ms, typical

1. To within 0.1 ppm of final frequency above 250 MHz or within 100 Hz below 250 MHz.

**Phase Offset:** *Phase is adjustable via HP-IB or from the front panel in nominal 0.1 degree increments.*

<b>Frequency Bands:</b>		
<b>Band</b>	<b>Frequency Range</b>	<b>N #</b>
1	250 kHz to ≤ 249.999 MHz	1
2	> 249.999 to ≤ 500 MHz	0.5
3	> 500 MHz to ≤ 1 GHz	1
4	> 1 to ≤ 2 GHz	2
5	> 2 to 4 GHz	4

## Sweep Modes

**Operating Modes:** Frequency Step, Amplitude Step, and Arbitrary List

**Dwell Time:** 1 ms to 60 s

**Number of Points:** 2 to 401

## Internal Reference Oscillator

Stability:		
	Standard (typical)	High Stability (Option 1E5)
Aging Rate	$< \pm 2 \text{ ppm/year}$	$< \pm 0.1 \text{ ppm/year}$ or $< \pm 0.0005 \text{ ppm/day}$ after 45 days
Temperature (0 to 55°C)	$< \pm 1 \text{ ppm}$	$< \pm 0.05 \text{ ppm, typical}$
Line Voltage	$< \pm 0.1 \text{ ppm}$ (+5%, -10%)	$< \pm 0.002 \text{ ppm, typical}$ (+5%, -10%)

### Timebase Reference Output:

**Frequency:** 10 MHz

**Amplitude:**  $> 0.35 \text{ V}_{\text{rms}}$  into 50Ω load

### External Reference Input:

**Frequency:** 1, 2, 5, 10 MHz  $\pm$  typically 10 ppm (typically 1 ppm, Opt. 1E5)

**Amplitude:**  $> 0.15 \text{ V}_{\text{rms}}$

**Input Impedance:** 50Ω

## Output

### Range:

**250 kHz to 1000 MHz:** +13 to -136 dBm

**> 1000 MHz to 3000 MHz:** +10 to -136 dBm

**> 3000 MHz to 4000 MHz:** +7 to -136 dBm

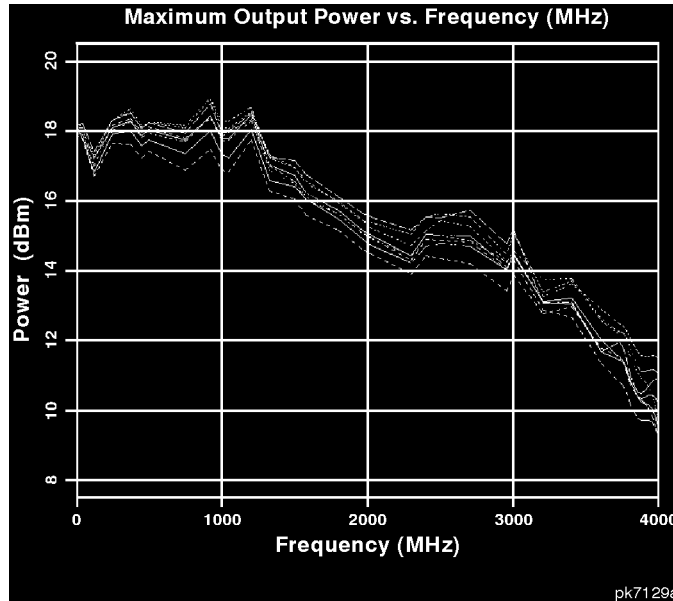

**Resolution:** 0.02 dB

**Attenuator Hold Level Range:**

**250 kHz to 1000 MHz:** 23 dB

**> 1000 MHz to 3000 MHz:** 20 dB

**> 3000 MHz to 4000 MHz:** 17 dB

<b>Level Accuracy<sup>1</sup>:</b>		
	<b>+7 to -127 dBm</b>	<b>&lt; -127 dBm</b>
<b>250 kHz to 2 GHz:</b>	±0.5 dB	±1.5 dB
<b>&gt; 2 to 4 GHz:</b>	±0.9 dB	±2.5 dB

1. For 23° ±5°C. Accuracy degrades by 0.02 dB per degree C over the full temperature range and by 0.3 dB above +7 dBm.

Specifications  
HP ESG Series Signal Generators Specifications

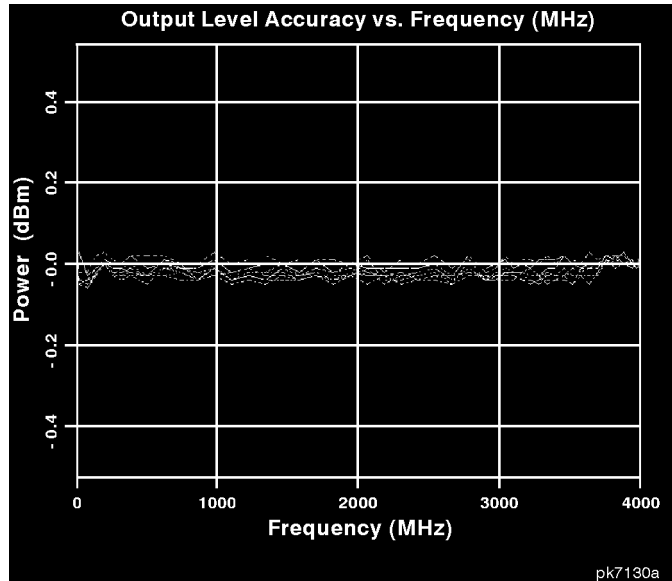

**Amplitude Switching Speed:** < 25 ms, typical

**When Using Power Search:** < 210 ms, typical

**Reverse Power Protection<sup>1</sup>:**

**250 kHz to 2000 MHz:** 50 watts

**> 2000 MHz to 4000 MHz:** 25 watts

**Maximum DC Voltage:** 50 V

1. The reverse power protection circuitry triggers at nominally 1 watt.

**SWR (typical):**

**250 kHz to 2000 MHz:** < 1.4:1

**> 2000 to 4000 MHz:** < 1.9:1

**Output Impedance:** 50Ω

## Spectral Purity

**SSB Phase Noise** (typical, at 20 kHz offset):

at 500 MHz: < -120 dBc/Hz

at 1000 MHz: < -116 dBc/Hz

at 2000 MHz: < -110 dBc/Hz

at 3000 MHz: < -104 dBc/Hz

at 4000 MHz: < -104 dBc/Hz

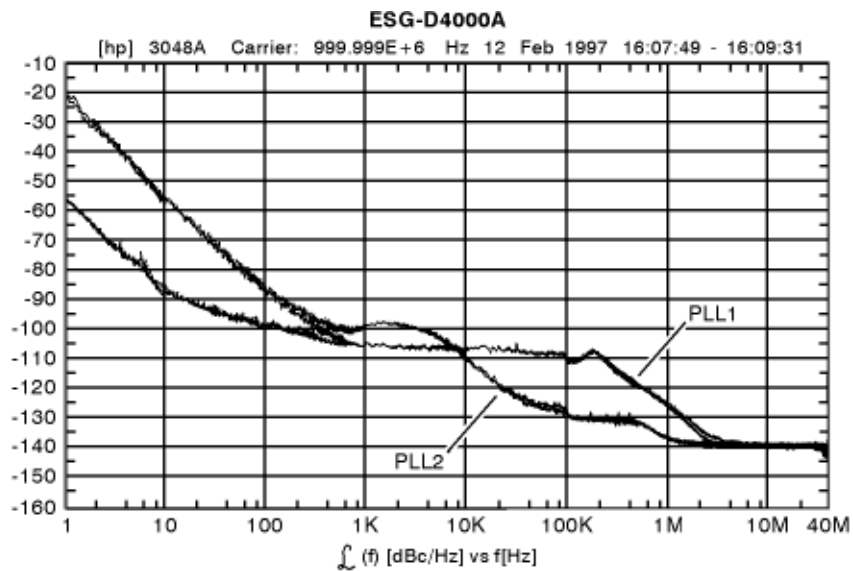

pk7138a

### Typical Phase Noise Modes 1 and 2 Single Sideband Phase Noise at 1 GHz

**Residual FM** (CW mode, 0.3 to 3 kHz BW, CCITT, rms):

**Phase Noise Mode 1:** < N x 2 Hz

**Phase Noise Mode 2:** < N x 4 Hz

**Harmonics** ( $\leq +4$  dBm output level): < -30 dBc



Specifications  
**HP ESG Series Signal Generators Specifications**

<b>Nonharmonics (&lt; +7 dBm output level)<sup>1</sup>:</b>		
At Offsets:	> 3 kHz	> 10 kHz ( <i>typical</i> )
<b>250 kHz to 1000 MHz:</b>	< -65 dBc	< -75 dBc
<b>&gt; 1000 to 2000 MHz:</b>	< -59 dBc	< -69 dBc
<b>&gt; 2000 MHz:</b>	< -53 dBc	< -33 dBc

1. Performance is typical for spurs at frequencies above the maximum operating frequency of the instrument. Performance typically is -60 dBc between 225 and 249.999 MHz. Specifications apply for FM deviations < 100 kHz and are not valid for  $\Phi$ M.

**Subharmonics:**

**≤ 1000 MHz:** None  
**> 1000 MHz:** < -40 dBc

**Frequency Modulation**

**Maximum Deviation:** N x 10 MHz

**Resolution:** 0.1% of deviation or 1 Hz, whichever is greater

**Deviation Accuracy:** < ±(3.5% of FM deviation setting + 20 Hz)  
 (1 kHz rate, deviation < N x 100 kHz)

Modulation Frequency Response <sup>1</sup> :		
Path	Rates (deviation = 100 kHz)	
	1 dB Bandwidth	3 dB Bandwidth (typical)
FM 1:	(dc/20 Hz to 100 kHz)	dc/5 Hz to 10 MHz
FM 2:	(dc/20 Hz to 100 kHz)	dc/5 Hz to 1 MHz

1. Since the internal modulation source operates over 0.1 Hz to 50 kHz, FM rates above 50 kHz must be supplied externally.

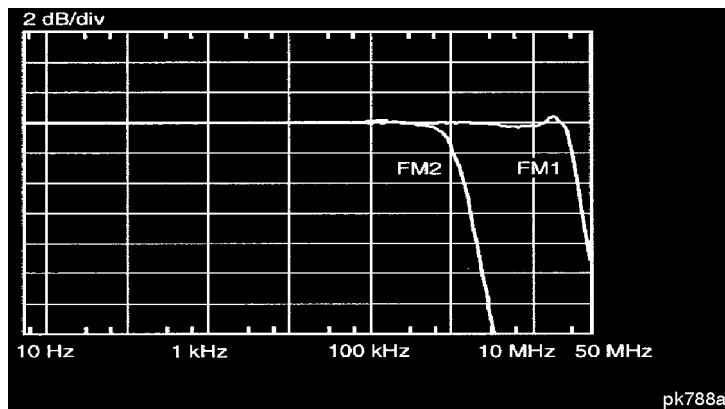

### Typical FM 1 and FM 2 Frequency Response

**Carrier Frequency Accuracy**      $\pm 0.1\%$  of set deviation + (N x 1 Hz)  
**Relative to CW in DCFM<sup>1</sup>:**

1. At the calibrated deviation and carrier frequency, within 5° C of ambient temperature at time of user calibration.

**Distortion** (1 kHz rate, THD, Deviations = N x 100 kHz):     < 1%

**External Inputs:**     Ext 1 or Ext 2

**Sensitivity:**     1 Vpk for indicated deviation

Specifications  
**HP ESG Series Signal Generators Specifications**

**Input Impedance:** 50Ω, nominal

**Paths:** FM 1 and FM 2 are summed internally for composite modulation. Either path may be switched to any one of the modulation sources: Int, Ext 1, Ext 2. The FM 2 path is limited to a maximum rate of 1 MHz. The FM 2 path must be set to a deviation less than FM 1.

## Phase Modulation

**Maximum Deviation:** N x 90 radians

**Resolution:** 0.1% of set deviation

**Deviation Accuracy (1 kHz rate):** < ±(5% of deviation + 0.01 radians)

<b>Modulation Frequency Response:</b>			
<b>Phase Modulation Mode</b>	<b>Maximum Deviation</b>	<b>Rates (3 dB BW)</b>	
		<b>ΦM1</b>	<b>ΦM2</b>
<b>Normal</b>	N x 90 radians:	dc - 100 kHz	dc - 100 kHz
<b>High Bandwidth</b>	N x 2π radians:	<i>dc - 1.5 MHz, typical</i>	<i>dc - 0.9 MHz, typical</i>
	N x π/2 radians:	<i>dc - 4 MHz, typical</i>	<i>dc - 1 MHz, typical</i>

**Distortion (1 kHz rate, THD, deviations < N x 90 radians):** < 1%

**External Inputs:** Ext 1 or Ext 2

**Sensitivity:** 1 Vpk for indicated deviation

**Input Impedance:** 50Ω, nominal

**Paths:**  $\Phi$ M 1 and  $\Phi$ M 2 are summed internally for composite modulation. Either path may be switched to any one of the modulation sources: Int, Ext 1, Ext2. The  $\Phi$ M 2 path is limited to a maximum rate of 1 MHz. The  $\Phi$ M 2 path must be set to a deviation less than  $\Phi$ M 1.

### Amplitude Modulation at $f_c > 500$ kHz

AM is typical above 3 GHz.

**Range** (envelope peak  $\leq$  maximum specified power): 0 to 100%

**Rates** (3 dB bandwidth): dc/10 Hz to 10 kHz

**Resolution:** 0.1%

**Accuracy** (1 kHz rate):  $< \pm(5\%$  of setting + 1%)

**Distortion** (1 kHz rate, THD):

**30% AM:**  $< 1.5\%$

**90% AM:**  $< 4\%$

**External Inputs:** Ext 1 or Ext 2

**Sensitivity:** 1 Vpk for indicated depth

**Input Impedance:**  $50\Omega$ , nominal

**Paths:** AM 1 and AM 2 are summed internally for composite modulation. Either path may be switched to any one of the modulation sources: Int, Ext 1, Ext 2.

## Pulse Modulation

**On/Off Ratio:**

$\leq 3$  GHz: > 80 dB

< 3 GHz: > 60 dB

**Rise/Fall Times:** *150 ns, typical*

**Minimum Width:**

**ALC On:** *2  $\mu$ s, typical*

**ALC Off:** *0.4  $\mu$ s, typical*

**Pulse Repetition Frequency:**

**ALC On:** *10 Hz to 250 kHz, typical*

**ALC Off:** *dc to 1.0 MHz, typical*

**Level Accuracy** (relative to CW)<sup>1</sup>:  $\pm 0.5$  dB, typical

1. With ALC off, specifications apply after the execution of power search. With ALC on, specifications apply for repetition rates < 10 kHz and pulse widths  $\geq 5$   $\mu$ s.

**External Input:** Ext 2

**Input Voltage:**

**RF On:** > +0.5 V, nominal

**RF Off:** < +0.5 V, nominal

**Input Impedance:** 50 $\Omega$ , nominal

**Internal Pulse Generator:**

**Squarewave Rate:** 0.1 Hz to 50 kHz

**Period:** 16  $\mu$ s to 30s

**Width:** 8  $\mu$ s to 30s

**Resolution:** 4  $\mu$ s

## Internal Modulation Source

Provides FM,  $\Phi$ M, and AM modulation signals and LF Out.

**Waveforms:** Sine, Square, Ramp, Triangle, and Noise

**Rate Range:**

**Sine:** 0.1 Hz to 50 kHz

**Square, Ramp, Triangle:** 0.1 Hz to 10 kHz

Specifications  
HP ESG Series Signal Generators Specifications

**Resolution:** 0.1 Hz

**Pulse Only:** 4  $\mu$ s

**Frequency Accuracy:** 0.005%

**Swept Sine Mode** (Frequency, Phase Continuous):

**Operating Modes:** Triggered or Continuous Sweeps

**Frequency Range:** 0.1 Hz to 50 kHz

**Sweep Time:** 1 ms to 65s

**Resolution:** 1 ms

**Dual Sinewave Mode:**

**Frequency Range:** 0.1 Hz to 50 kHz

**Amplitude Ratio:** 0 to 100%

**Resolution:** 0.1%

## LF Out (Internal Modulation Source)

**Amplitude:** 0 to 3 Vpk into 50 $\Omega$

**Output Impedance:** < 1 $\Omega$

## External Modulation Inputs

**Modulation Types:**

**Ext 1:** FM,  $\Phi$ M, and AM

**Ext 2:** FM,  $\Phi$ M, AM, and Pulse

**High/Low Indicator:** *Indicator is activated when input level error exceeds 3% (nominal)*  
(100 Hz to 10 MHz BW, AC-coupled inputs only)

## Simultaneous Modulation

All modulation types may be simultaneously enabled, except FM with  $\Phi$ M, AM, FM and  $\Phi$ M can sum simultaneous inputs from any two sources (Int, EXT 1, and EXT 2.) Any given source (Int, EXT 1, or EXT 2) may only be routed to one activated modulation type.

## Remote Programming

**Interface:** HP-IB (IEEE-488.2-1987) with Listen and Talk. RS-232

**Control Languages:** SCPI version 1992.0, also compatible with HP 8656B and 8657A/B/C/D/J<sup>1</sup> mnemonics.

1. HP ESG series does not implement HP 8657A/B 'Standby' or 'On' (R0 or R1, respectively) mnemonics.

**Functions Controlled:** All front panel functions except power switch and knobs.

**IEEE-488 Functions:** SH1, AH1, T6, TE0, L4, LE0, SR1, RL1, PP0, DC1, DT0, C0, E2

## ISO Compliant

The HP ESG Series RF signal generators are manufactured in an ISO 9001 registered facility in concurrence with Hewlett-Packard's commitment to quality.



## General

**Power Requirements:** 90 to 254 V; 50, 60, or 400 Hz; 200 W maximum

**Operating Temperature Range:** 0 to 55° C

**Storage Temperature Range:** -40 to +71 ° C

**Shock and Vibration:** Meets MIL STD 28800E Type III, Class 3

**Leakage:** Conducted and radiated interference meets MIL STD 461B RE02 Part 2 and CISPR 11. *Leakage is typically < 1  $\mu$ V (nominally 0.1  $\mu$ V with a 2-turn loop) at  $\leq$  1000 MHz, measured with a resonant dipole antenna one inch from any surface with output level < 0 dBm (all inputs/outputs properly terminated).*

**Storage Registers:** Up to 100 storage registers with sequence and register number displayed. Up to 10 sequences available.

**Weight:** < 12.7 kg (28 lb.) net, < 21 kg (46 lb.) shipping

**Dimensions:** 133 mm H x 426 mm W x 432 mm D  
(5.25 in. H x 16.8 in. W x 17 in. D)

## Accessories

Transit Case, HP Part Number 9211-1296

HP 83300A Remote Interface

## Options

0B0	Delete Manual Set
0B1	Extra Manual Set
0BV	Add Component Level Information Package
0BW	Add Service Documentation (Assembly Level Repair)
0BX	Add Service Documentation and Component Level Information Package
1CM	Rack Flange Kit (without handles)
1CN	Front Handle Kit
1CP	Rack Flange Kit (with handles)
1E5	Add High Stability timebase
1EM	Move All Front Panel Connectors to Rear Panel
W30	Three Year Warranty

Specifications  
**HP ESG Series Signal Generators Specifications**

---

## 2 Equipment Required

**\_\_\_\_\_**  
This chapter contains a list of all the recommended equipment required to perform the performance tests and adjustments for the HP ESG Series Signal Generators.

---

## Required Equipment

- HP 8902A Measuring Receiver<sup>1</sup>
  - FM accuracy:  $\pm 2\%$  of reading  $\pm 1$  digit
  - AM accuracy:  $\pm 2\%$  of reading  $\pm 1$  digit
  - Range: 250 kHz to 1300 MHz
  - Filters: 300 Hz high-pass and 15 kHz and 3 kHz low-pass
  - Detectors: Peak+
- HP 54610B Digital Oscilloscope<sup>1</sup>
  - Bandwidth: 500 MHz
- HP 5071A Primary Frequency Standard
  - Frequency: 10 MHz
  - Stability:  $> 1 \times 10^{-10}$ /year
- HP 8903B Option 051 Audio Analyzer<sup>1</sup>
  - Distortion accuracy:  $\pm 1$  dB
  - Residual distortion:  $-80$  dB at 80 kHz BW
  - 30 kHz low-pass filter
  - AC level accuracy:  $\pm 4\%$
- HP 8563E Spectrum Analyzer<sup>1</sup>
  - Frequency range: 100 kHz to 4000 MHz
  - Relative level accuracy (harmonic and spurious measurements)  $\pm 2$  dB
  - Displayed average noise level (1 Hz BW)  $-110$  dBm at 100 kHz,  $-130$  dBm at 1 MHz to 10 MHz, and  $-134$  dBm at 0.01 to 4 GHz
  - 1 Hz digital resolution BW filter (required for power accuracy)
  - RF input VSWR: 1:1.5
  - External timebase input
- HP 8663A Signal Generator<sup>1</sup>
  - Frequency range: 11.5 MHz to 2500 MHz
  - Output level:  $+16$  dBm
  - Meets HP 8663A single-sideband phase noise specifications

1. Equipped with HP-IB computer interface.

- HP 8904A Function Generator<sup>1</sup>
  - Frequency range (sinewave): 0 Hz to 600 kHz
  - AC Amplitude (sinewave only):
    - Range: 0 to 10 Vp-p into a 50 $\Omega$  load
    - Flatness: (> 630 mVp-p into 50 $\Omega$ ):  $\pm 0.1\%$  ( $\pm 0.009$  dB), 0.1 Hz to 100 kHz
- HP 5350B Frequency Counter<sup>1</sup>
  - Frequency range: 400 Hz 4000 MHz
  - Resolution: 1 Hz
  - Frequency accuracy (same as timebase):  $\pm 1.5$  Hz
  - External timebase input: > 10 MHz
- HP 53132A Option 050 Universal Counter<sup>1</sup>
  - Frequency range: 4 GHz
  - Resolution: 0.1 Hz
  - External timebase input
- HP 33120A Option 001 Arbitrary Waveform Generator<sup>1</sup> (2)
  - No Substitution
- HP 438A Power Meter<sup>1</sup>
  - Instrumentation accuracy:  $\pm 0.5\%$
  - Power reference accuracy: 0.9%
- HP 8482A Power Sensor
  - Frequency range: 100 kHz to 4000 MHz
  - Power range: -30 dBm to +13 dBm
  - Maximum SWR: 100 kHz to 300 kHz: 1:1.6, 300 kHz to 1 MHz: 1:1.12, 1 MHz to 2 GHz: 1:1.1, 2 GHz to 4 GHz: 1:1.3
  - Calibration factor accuracy (RSS):  $\leq 1.6\%$
- HP 8447F Preamplifier-Amplifier
  - Frequency range: 100 kHz to 1.3 GHz,
  - Gain (mean, per channel): 22 dB  $\pm 1.5$  dB (20 ° to 30 °C)
- HP 8449B Preamplifier
  - Frequency range: 1.0 to 26.5 GHz
  - Gain (mean, per channel):  $\leq 26$  dB (20 ° to 30 °C)
  - Noise figure: 1.0 to 26.5 GHz ( $\leq 8.5$  dB typical) 7 dB
- MD/MDC-174 Mixer
  - Frequency range: 0.001 to 2.8 GHz

1. Equipped with HP-IB computer interface.

## Equipment Required

### Required Equipment

- MD/MDC-164 Mixer  
Frequency range: 0.5 to 9 GHz
- HP 8491A/B Option 006 Attenuator  
Attenuation: 6 dB
- HP 3458A Digital Multimeter<sup>1</sup>  
DC Volts: 0.1 V to 100 V  
Input resistance: 10  $\Omega$  to 1 K $\Omega$
- HP 8491A/B Option 010 Attenuator  
Attenuation: 10 dB
- HP Vectra Personal Computer  
CPU: 386 (or better)  
Clock: 33 MHz (or faster)  
RAM: 8Mb (or more)  
3.5" floppy disk drive  
350 Mb (or more) hard drive  
16-color VGA monitor  
MS Windows® 3.X (Microsoft Windows is a registered trademark of Microsoft Corp.)
- HP LaserJet 5L Printer  
MS Windows supported
- HP 82341C HP-IB Interface Card  
No Substitution

1. Equipped with HP-IB computer interface.

---

## 3 Operation Verification

---

This chapter provides procedures that will either ensure that the signal generator is operating correctly or will help to point to problem areas if it is not. Operation verification does not ensure performance to specifications but should provide a level of confidence that the instrument is operating to specifications within a minimum amount of time. Operation verification is appropriate for incoming inspection, after repair when a full calibrated performance is not required, or whenever the integrity of the instrument is in question.



## Verification Procedures

Perform the following procedures in the order they are presented.

1. Power On the Signal Generator and Check for Error Messages
2. Frequency Range and Accuracy Check
3. Power Level Accuracy Check
4. FM Accuracy Check
5. AM Accuracy Check

## Equipment Required

- HP 5350A Frequency Counter
- HP 438A Power Meter
- HP 8482A Power Sensor
- HP 8563E Spectrum Analyzer
- HP 8491A/B Option 006 Attenuator (6 dB)
- HP 8491A/B Option 010 Attenuator (10 dB)
- HP 8902A Measuring Receiver

## 1. Power On the Signal Generator and Check for Error Messages

This procedure verifies that the signal generator powers up and that the internal instrument check identifies no errors. The internal check evaluates the correctness of operation and returns an error message if a problem is detected.

1. Turn power on to the signal generator by pressing the power switch. The green LED will light. Let the instrument warm up for one hour.
2. Cycle the power to the signal generator. The green LED should again be lit and the instrument will perform a check.
3. When the display is lit, check to see if the **ERR** annunciator is turned on.
4. If the **ERR** annunciator is turned on, review the error messages in the queue by pressing **Utility, Error Info, View Next Error Message**. The first error message in the queue will be shown in the text area of the display. Refer to the service guide for information about the error message.

If there is more than one error message (each message will be designated as 1 of *n*), continue pressing the **View Next Error Message** softkey until you have seen all of the messages.

5. When you have resolved all of the error messages, press **Clear Error Queue(s)** to delete the messages. Then restart this procedure at step two.

---

**NOTE:**

For instruments with Option 1E5, **ERROR 514, Reference Oven Cold** will occur whenever the signal generator is first connected to AC line power. The **OVEN COLD** annunciator and the **ERR** annunciator will both turn on. The **OVEN COLD** annunciator will automatically clear after approximately 5 minutes. The error queue *cannot* be cleared, however, until the **OVEN COLD** annunciator has turned off.

---

## 2. Frequency Range and Accuracy Check

Frequency range is tested by determining the frequency accuracy relative to the timebase at the frequency limits.

### Connect the Test Equipment

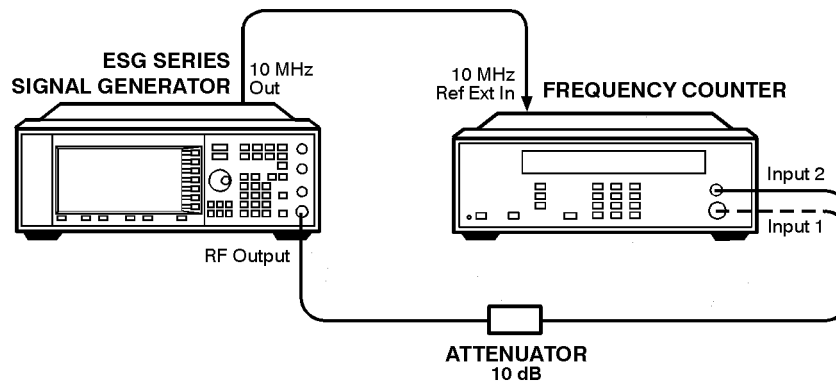

wk751a

Figure 3-1. Frequency Range and Accuracy Equipment Setup

### Configure the Signal Generator

1. Preset the signal generator to normal (factory-defined) preset conditions.
2. For frequencies < 10 MHz:
  - a. Set the amplitude to 10 dBm. Press **Amplitude**. Enter 10 dBm using the numeric keypad and pressing the **dBm** terminator softkey.
  - b. Turn the RF output on. Press **RF On/Off**. The **RF ON** annunciator should be turned on.
3. For frequencies > 10 MHz:
  - a. Set the amplitude to 0 dBm. Press **Amplitude**. Enter 0 dBm using the numeric keypad and pressing the **dBm** terminator softkey.
  - b. Turn the RF output on. Press **RF On/Off**. The **RF ON** annunciator should be turned on.

### Configure the Frequency Counter

1. For frequencies < 10 MHz use Input 2. Press **1 MΩ**.
2. For frequencies > 10 MHz and ≤ 500 MHz use Input 2. Press **50 Ω**.

- For frequencies > 500 MHz use Input 1. Press **AUTO**.

---

**NOTE:** Set the gate time of > 5 seconds for maximum counter accuracy. Verify that the counter is phase-locked to the 10 MHz external reference.

---

### Measure the Frequency Accuracy

- Set the frequencies shown in Table 3-1 (to the maximum frequency of your signal generator).
- For each measurement point, measure the carrier frequency with modulation turned off. Press **Mod On/Off**. The **MOD OFF** annunciator should be turned on.
- Record the measured frequency in Table 3-1.
- Compute the error (difference) and compare it to the corresponding limits.

**Table 3-1. Frequency Accuracy Measurement Points**

Frequency (MHz)	Limits		
	Lower (Hz)	Measured (Hz)	Upper (Hz)
0.25	99 999.		100 001.
0.5	499 999.		500 001.
1	999 999.		1 000 001.
10	9 999 999.		10 000 001.
50	49 999 999.		50 000 001.
100	99 999 999.		100 000 001.
500	499 999 999.		500 000 001.
1000	999 999 999.		1 000 000 001.
2000	1 999 999 999.		2 000 000 001.
3000	2 999 999 999.		3 000 000 001.
4000	3 999 999 999.		4 000 000 001.

### 3. Power Level Accuracy Check

Conducting this check will provide a high level of confidence and a verification that the signal generator's power level circuitry is functioning correctly. The check does *not* test the signal generator to warranted specifications. Test points have been reduced and the limits are degraded in order to minimize measurement time and take into account a broad range of measurement uncertainties. To have the signal generator tested to warranted specifications, a complete power level accuracy performance test is required. Contact your nearest HP service center for information concerning calibration.

#### Connect the Test Equipment for Setup 1

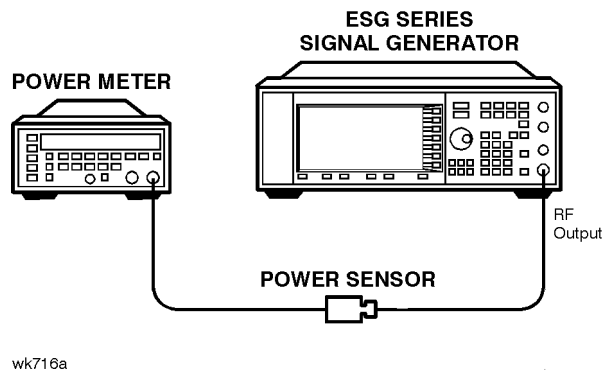

Figure 3-2. Power Accuracy Equipment Setup 1

#### Configure the Signal Generator

1. Preset the signal generator to normal (factory-defined) preset conditions.
2. Set the frequency to 277 kHz. Press **Frequency**. Enter 277 kHz using the numeric keypad and pressing the **kHz** terminator softkey.
3. Set the amplitude to 13 dBm. Press **Amplitude**. Enter 13 dBm using the numeric keypad and pressing the **dBm** terminator softkey.
4. Turn modulation off. Press **Mod On/Off**. The **MOD OFF** annunciator should be turned on.
5. Turn the RF output on. Press **RF On/Off**. The **RF ON** annunciator should be turned on.

#### Configure the Power Meter

1. Zero and calibrate the power meter.
2. Set the power meter to measure absolute log power (dBm). Make sure to set the power meter cal factor as necessary for each frequency.

**Measure the Power Level Accuracy**

1. Set the power levels and the frequencies shown in Table 3-2 (to the maximum frequency of your signal generator).
2. Record the measured power level in Table 3-2 and compare it to the corresponding limits.

**Table 3-2. Power Level Accuracy Measurement Points for Setup 1**

Frequency Setting	Power Level Setting	Lower Limit	Measured Power	Upper Limit
277 kHz	+13 dBm	12.2		13.8
	+7 dBm	6.5		7.5
	0 dBm	-0.5		0.5
	-5 dBm	-5.5		-4.5
	-15 dBm	-15.5		-14.5
2.516 MHz	+13 dBm	12.2		13.8
	+7 dBm	6.5		7.5
	0 dBm	-0.5		0.5
	-5 dBm	-5.5		-4.5
	-15 dBm	-15.5		-14.5
270.1 MHz	+13 dBm	12.2		13.8
	+7 dBm	6.5		7.5
	0 dBm	-0.5		0.5
	-5 dBm	-5.5		-4.5
	-15 dBm	-5.5		-14.5
510.1 MHz	+13 dBm	12.2		13.8
	+7 dBm	6.5		7.5
	0 dBm	-0.5		0.5
	-5 dBm	-5.5		-4.5
	-15 dBm	-15.5		-14.5

**Table 3-2. Power Level Accuracy Measurement Points for Setup 1**

<b>Frequency Setting</b>	<b>Power Level Setting</b>	<b>Lower Limit</b>	<b>Measured Power</b>	<b>Upper Limit</b>
990.1 MHz	+13 dBm	12.2		13.8
	+7 dBm	6.5		7.5
	0 dBm	-0.5		0.5
	-5 dBm	-5.5		-4.5
	-15 dBm	-15.5		-14.5
1350.1 MHz	+10 dBm	9.2		10.8
	+7 dBm	6.5		7.5
	0 dBm	-0.5		0.5
	-5 dBm	-5.5		-4.5
	-15 dBm	-15.5		-14.5
1950.1 MHz	+10 dBm	9.2		10.8
	+7 dBm	6.5		7.5
	0 dBm	-0.5		0.5
	-5 dBm	-5.5		-4.5
	-15 dBm	-15.5		-14.5
2310.1 MHz	+10 dBm	8.8		11.2
	+7 dBm	6.1		7.9
	0 dBm	-0.9		0.9
	-5 dBm	-5.9		-4.1
	-15 dBm	-15.9		-14.1

**Table 3-2. Power Level Accuracy Measurement Points for Setup 1**

Frequency Setting	Power Level Setting	Lower Limit	Measured Power	Upper Limit
2985.1 MHz	+10 dBm	8.8		11.2
	+7 dBm	6.1		7.9
	0 dBm	-0.9		0.9
	-5 dBm	-5.9		-4.1
	-15 dBm	-15.9		-14.1
3225.1 MHz	+7 dBm	6.1		7.9
	0 dBm	-0.9		0.9
	-5 dBm	-5.9		-4.1
	-15 dBm	-15.9		-14.1
4000 MHz	+7 dBm	6.1		7.9
	0 dBm	-0.9		0.9
	-5 dBm	-5.9		-4.1
	-15 dBm	-15.9		-14.1

**Connect the Test Equipment for Setup 2**

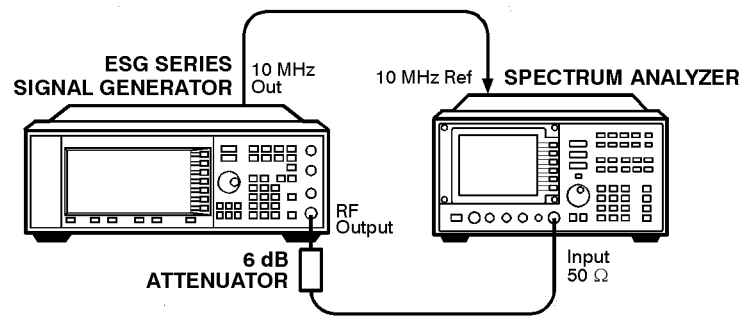

wk742a

**Figure 3-3. Power Accuracy Equipment Setup 2**



### Configure the Signal Generator

1. Set the frequency to 277 kHz. Press **Frequency**. Enter 277 kHz using the numeric keypad and pressing the **kHz** terminator softkey.
2. Set the amplitude to –15 dBm. Press **Amplitude**. Enter –15 dBm using the numeric keypad and pressing the **dBm** terminator softkey.

### Configure the Spectrum Analyzer

1. Preset the spectrum analyzer.
2. Set the analyzer to external 10 MHz reference.
3. Set the center frequency to 277 kHz.
4. Set the frequency span to 100 Hz. (This will result in a 1 Hz resolution bandwidth with a digital filter.)

### Measure the Power Level Accuracy

1. Connect the signal generator's RF OUTPUT through the 6 dB attenuator to the spectrum analyzer's RF input.
2. Transfer the power level results for each frequency at –15 dBm from Table 3-2 to Table 3-3.
3. On the spectrum analyzer, select Marker Normal Mode and the Select the Peak Search function. This activates the marker and sets it to the signal peak.
4. On the spectrum analyzer, ensure that the marker is at the signal peak and use the MKR-> menu to set the marker to the reference level. If necessary, select Peak Search to ensure that the marker is at the signal peak.
5. With the marker at signal peak, select the Marker Delta function. This will set the marker to measure relative amplitude from a reference of 0 dB. If the marker reads other than 0 dB, select Marker Normal, Peak Search, and Marker Delta until the marker reads 0 dB.
6. Decrease the signal generator amplitude in 10 dB steps to –85 dBm. At each 10 dB step, select Peak Search to ensure that the marker is at the signal peak.
7. Measure and record the result for each of the frequencies listed in Table 3-3 (to the maximum frequency of your signal generator).
8. Return the spectrum analyzer reference level back to –15 dBm and the signal generator amplitude to –15 dBm. Set the signal generator frequency and the spectrum analyzer's center frequency to the next frequency listed in Table 3-3 and repeat the process from step 3 until all of the frequencies have been measured.

**Calculate the Actual Power Level**

1. Calculate and record the actual power level as the sum of the power meter reading at -15 dBm and the spectrum analyzer's marker value.

For example:

-15 dBm power meter reading at 2.516 MHz = -14.95 dBm

spectrum analyzer marker at 2.516 MHz and power level set to -85 dBm = -70.17 dB

Actual Power Level at 2.516 MHz and -85 dBm:

$$(-14.95) + (-70.17) = -85.12 \text{ dBm}$$

**Table 3-3. Power Level Accuracy Measurement Points for Setup 2**

Frequency Setting	Power Level Setting	Power Mtr Reading for -15 dBm	Spectrum Analyzer Marker (dB)	Lower Limit	Measured Power	Upper Limit
277 kHz	-15 dBm		0 (Ref)	N/A	N/A	N/A
	-25 dBm			-26		-24
	-35 dBm			-36		-34
	-45 dBm			-46		-44
	-55 dBm			-56		-54
	-65 dBm			-66		-64
	-75 dBm			-76		-74
	-85 dBm			-86		-84
2.516 MHz	-15 dBm		0 (Ref)	N/A	N/A	N/A
	-25 dBm			-26		-24
	-35 dBm			-36		-34
	-45 dBm			-46		-44
	-55 dBm			-56		-54
	-65 dBm			-66		-64
	-75 dBm			-76		-74
	-85 dBm			-86		-84

**Table 3-3. Power Level Accuracy Measurement Points for Setup 2**

Frequency Setting	Power Level Setting	Power Mtr Reading for -15 dBm	Spectrum Analyzer Marker (dB)	Lower Limit	Measured Power	Upper Limit
270.1 MHz	-15 dBm		0 (Ref)	N/A	N/A	N/A
	-25 dBm			-26		-24
	-35 dBm			-36		-34
	-45 dBm			-46		-44
	-55 dBm			-56		-54
	-65 dBm			-66		-64
	-75 dBm			-76		-74
	-85 dBm			-86		-84
510.1 MHz	-15 dBm		0 (Ref)	N/A	N/A	N/A
	-25 dBm			-26		-24
	-35 dBm			-36		-34
	-45 dBm			-46		-44
	-55 dBm			-56		-54
	-65 dBm			-66		-64
	-75 dBm			-76		-74
	-85 dBm			-86		-84
990.1 MHz	-15 dBm		0 (Ref)	N/A	N/A	N/A
	-25 dBm			-26		-24
	-35 dBm			-36		-34
	-45 dBm			-46		-44
	-55 dBm			-56		-54
	-65 dBm			-66		-64
	-75 dBm			-76		-74
	-85 dBm			-86		-84

**Table 3-3. Power Level Accuracy Measurement Points for Setup 2**

Frequency Setting	Power Level Setting	Power Mtr Reading for -15 dBm	Spectrum Analyzer Marker (dB)	Lower Limit	Measured Power	Upper Limit
1350.1 MHz	-15 dBm		0 (Ref)	N/A	N/A	N/A
	-25 dBm			-26		-24
	-35 dBm			-36		-34
	-45 dBm			-46		-44
	-55 dBm			-56		-54
	-65 dBm			-66		-64
	-75 dBm			-76		-74
	-85 dBm			-86		-84
1950.1 MHz	-15 dBm		0 (Ref)	N/A	N/A	N/A
	-25 dBm			-26		-24
	-35 dBm			-36		-34
	-45 dBm			-46		-44
	-55 dBm			-56		-54
	-65 dBm			-66		-64
	-75 dBm			-76		-74
	-85 dBm			-86		-84
2310.1 MHz	-15 dBm		0 (Ref)	N/A	N/A	N/A
	-25 dBm			-26		-24
	-35 dBm			-36		-34
	-45 dBm			-46		-44
	-55 dBm			-56		-54
	-65 dBm			-66		-64
	-75 dBm			-76		-74
	-85 dBm			-86		-84

**Table 3-3. Power Level Accuracy Measurement Points for Setup 2**

Frequency Setting	Power Level Setting	Power Mtr Reading for -15 dBm	Spectrum Analyzer Marker (dB)	Lower Limit	Measured Power	Upper Limit
2985.1 MHz	-15 dBm		0 (Ref)	N/A	N/A	N/A
	-25 dBm			-26		-24
	-35 dBm			-36		-34
	-45 dBm			-46		-44
	-55 dBm			-56		-54
	-65 dBm			-66		-64
	-75 dBm			-76		-74
	-85 dBm			-86		-84
	3225.1 MHz	-15 dBm		0 (Ref)	N/A	N/A
-25 dBm				-26		-24
-35 dBm				-36		-34
-45 dBm				-46		-44
-55 dBm				-56		-54
-65 dBm				-66		-64
-75 dBm				-76		-74
-85 dBm				-86		-84
4000 MHz		-15 dBm		0 (Ref)	N/A	N/A
	-25 dBm			-26		-24
	-35 dBm			-36		-34
	-45 dBm			-46		-44
	-55 dBm			-56		-54
	-65 dBm			-66		-64
	-75 dBm			-76		-74
	-85 dBm			-86		-84

## 4. FM Accuracy Check

### Connect the Test Equipment

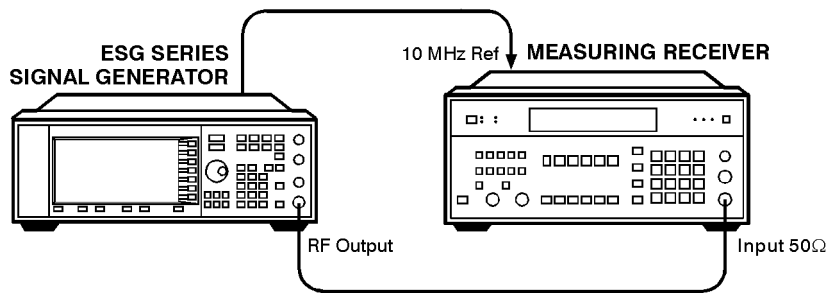

wk719a

Figure 3-4. FM Accuracy Equipment Setup

### Configure the Signal Generator

1. Preset the signal generator to normal (factory-defined) preset conditions.
2. Enable FM. Press **FM/ΦM**, **FM Off On**. The **FM** annunciator should turn on.
3. Set the FM rate to 1 kHz. Press **FM Rate** and enter 1 kHz using the numeric keypad and pressing the **kHz** terminator softkey.
4. Set the FM deviation to 100 kHz. Press **FM Dev** and enter 100 kHz using the numeric keypad and pressing the **kHz** terminator softkey.
5. Set the amplitude to 7 dBm. Press **Amplitude** and enter 7 dBm using the numeric keypad and pressing the **dBm** terminator softkey.
6. Check to be sure that modulation is turned on. The **MOD ON** annunciator should be turned on. If it is not, press **Mod On/Off**.
7. Turn on the RF output. Press **RF On/Off**. The **RF ON** annunciator should be turned on.

### Configure the Measuring Receiver

1. Reset the measuring receiver.
2. Set the measuring receiver to FM mode.
3. Turn on Peak+ detector.
4. Turn on the 300 Hz high-pass filter.
5. Turn on the 3 kHz low-pass filter.

### Measure the Deviations

1. Set the signal generator to the frequencies shown in Table 3-4.
2. Record the deviations measured and compare them to the limits shown in Table 3-4.

**Table 3-4. FM Accuracy Measurement Points**

Frequency (MHz)	Deviation (kHz)	Limits (kHz)		
		Lower	Measured	Upper
500.001	100 kHz	96.48		103.52
750	100 kHz	96.48		103.52
1000	100 kHz	96.48		103.52

## 5. AM Accuracy Check

### Connect the Test Equipment

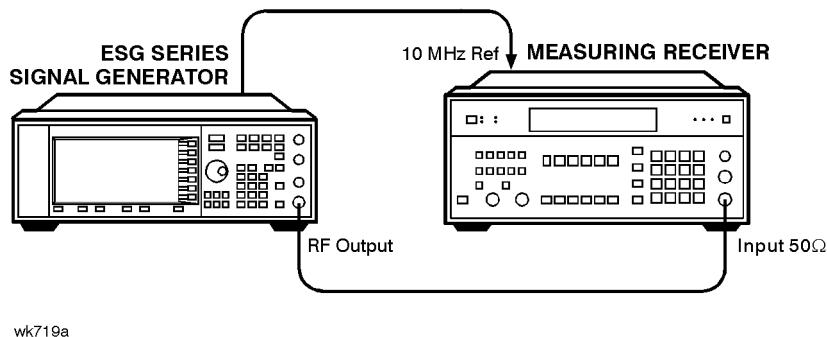

Figure 3-5. AM Accuracy Equipment Setup

### Configure the Signal Generator

1. Preset the signal generator to normal (factory-defined) preset conditions.
2. Enable AM. Press **AM**, **AM Off On**. The **AM** annunciator should turn on.
3. Set the AM rate to 1 kHz. Press **AM Rate** and enter 1 kHz using the numeric keypad and pressing the **kHz** terminator softkey.
4. Set the amplitude to +7 dBm. Press **Amplitude** and enter +7 dBm using the numeric keypad and pressing the **dBm** terminator softkey.
5. Check to be sure that modulation is turned on. The **MOD ON** annunciator should be turned on. If it is not, press **Mod On/Off**.
6. Turn on the RF output. Press **RF On/Off**. The **RF ON** annunciator should be turned on.

### Configure the Measuring Receiver

1. Reset the measuring receiver.
2. Set the measuring receiver to AM mode.
3. Turn on Peak+ detector.
4. Turn on the 300 Hz high-pass filter.
5. Turn on the 3 kHz low-pass filter.

### Measure the Deviations

1. Set the signal generator to the frequencies, and depths shown in Table 3-5.
2. Record the AM depths measured and compare them to the limits shown in Table 3-5.



**Table 3-5. AM Accuracy Measurement Points**

Frequency (MHz)	Depth (%)	Limits (%)		
		Lower	Measured	Upper
200	30	27.5		32.5
200	90	84.5		95.5
300	30	27.5		32.5
300	90	84.5		95.5
501	30	27.5		32.5
501	90	84.5		95.5
750	30	27.5		32.5
750	90	84.5		95.5
1000	30	27.5		32.5
1000	90	84.5		95.5

---

## 4 Service Software

---

The ESG Series Support Software contains the program and supporting files necessary to run the automated performance tests and adjustments for your signal generator. This chapter lists the equipment required to run the software, and gives instructions for installing and using the software. This information includes a short description for each adjustment. For a description of the individual performance tests, refer to the “Performance Tests” chapter.

---

## Required Test Equipment

The following equipment is required to run the software:

- Personal Computer with the following specifications:
  - 386/33 MHz CPU, 8 Mbytes RAM
  - 350 Mbyte Hard Drive
  - 16-Color VGA Monitor
- MS Windows® 3.X
- 2 Button Mouse (optional)
- Printer, MS Windows-Supported (for hardcopy documentation of test results)
- HP 82341C HP-IB Interface Card
  - HP SICL Libraries must be installed and configured

Microsoft Windows is a registered trademark of Microsoft Corp.

## Installing the ESG Series Support Software

Follow this procedure to install the ESG Series Support Software on your personal computer.

1. Insert the ESG Series Support Software disk (HP part number E4400-10001) into a 3.5 inch disk drive.
2. In the MS Windows File Manager program, select the drive where the software disk resides.
3. Double-click **setup.exe** to start installation.
4. A window appears showing the default drive and directory where the program will be installed. If you prefer, you can change the path at this time. When you are satisfied with the path, press **Continue** to begin installation. If you do *not* want to install the software after all, press **Exit Install**.
5. A setup window displays the completion status (in percent) of the installation process. Press **Cancel** at any time to abort installation.
6. When the installation is complete, a **readme** file is displayed. This file contains information about the latest updates to the software. When you have finished reading the file, press **Continue**.
7. A window appears announcing the completion of the installation process and indicating that the application is properly installed. Click **OK**.
8. An applications group titled ESG Series Support Software is created with a **testexec.exe** icon. The installation process is now complete.

---

## ESG Series Support Software Administration

The following section shows you how to administer and run the ESG Series Support Software. The software's administrative functions allow for the addition or removal of all necessary test equipment, software drivers, and test procedures. This would include additional software drivers (as they are released) to extend the range of tests and equipment supported by the ESG Series test set, or maintenance releases of the current drivers.

### Software Configuration

Follow the instructions below to configure the software to run in either User mode or Administration mode.

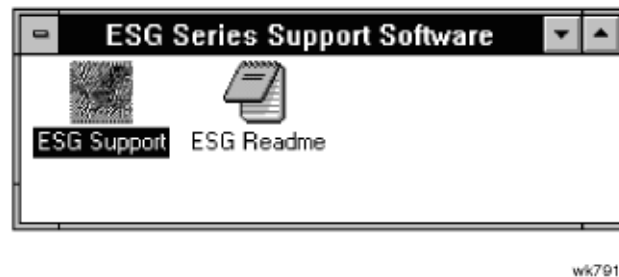

**Figure 4-1.** ESG Series Support Software Window

1. Double click on the ESG Support icon and the **User Information** window appears. The support software has two configurations: User and Admin. The following sections explain the difference between the two configurations.

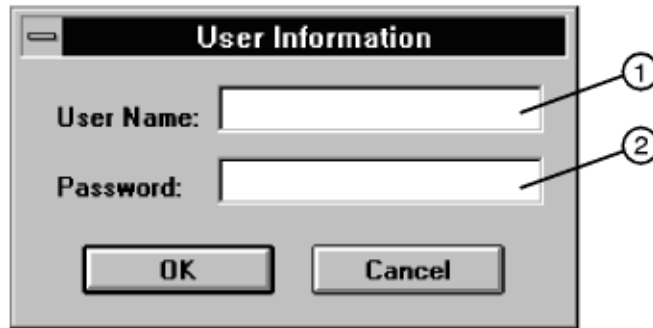

wk755a

**Figure 4-2. The User Information Window**

### **The User Configuration**

Logging on in User Configuration only allows access to the instrument's performance tests and adjustments. Refer to the section titled, "Running the Performance Tests" in the chapter, "Performance Tests."

### **The Administration Configuration**

Logging on in Administration Configuration supports all administrative functions including the addition of new equipment and the installation of test procedures and device drivers.

1. Refer to Figure 4-2 and fill in the fields in the **User Information** window:
  - a In the **User Name** field (item 1), type in the word **Admin**.
  - b In the **Password** field (item 2), type in the word **Falcon**.
2. Click **OK**. (**Cancel** closes the software application.)

### **Adding Test Equipment**

Before any performance tests can be run, your specific test equipment must be entered into the software database containing the serial numbers, calibration dates, HP-IB address, and traceability information for each individual component. Only equipment which has been entered into the system will be available for the test equipment selection process during the test setup. To add test equipment, follow the instructions below:

1. Refer to Figure 4-3. In the **File** drop-down menu, select **Test Equipment** (item 4).

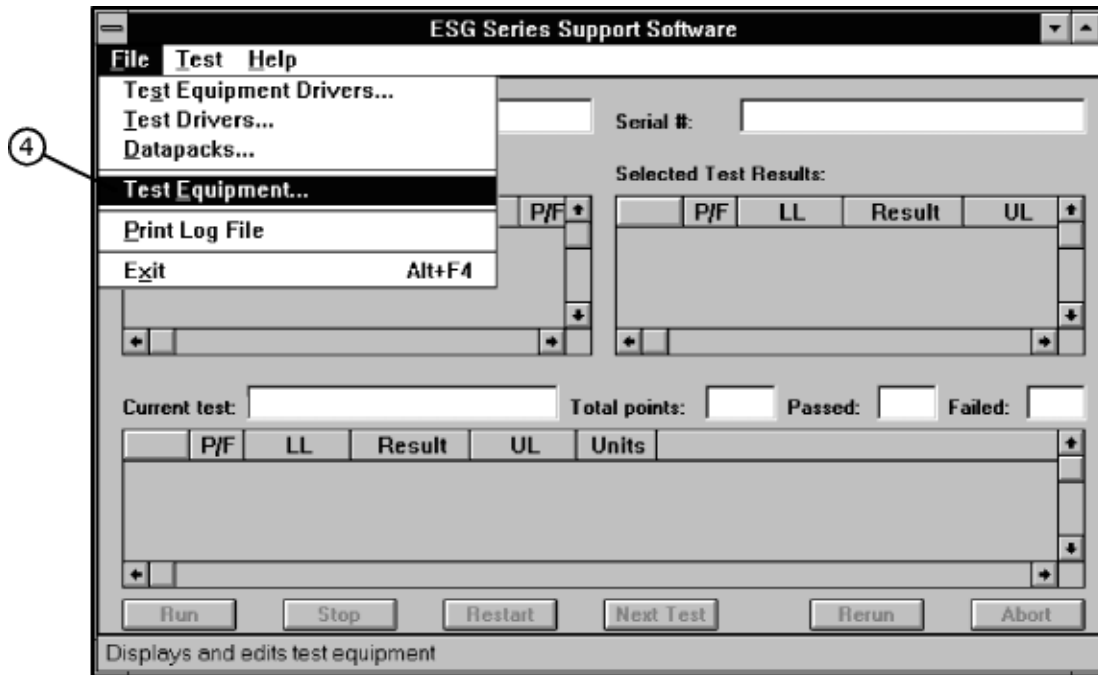

wk776a

Figure 4-3. Test Equipment Drivers in the File Drop-Down Menu

2. Refer to Figure 4-4. In the **Test Equipment** dialog box, select the **Device Type** for the new equipment you are adding (item 5).

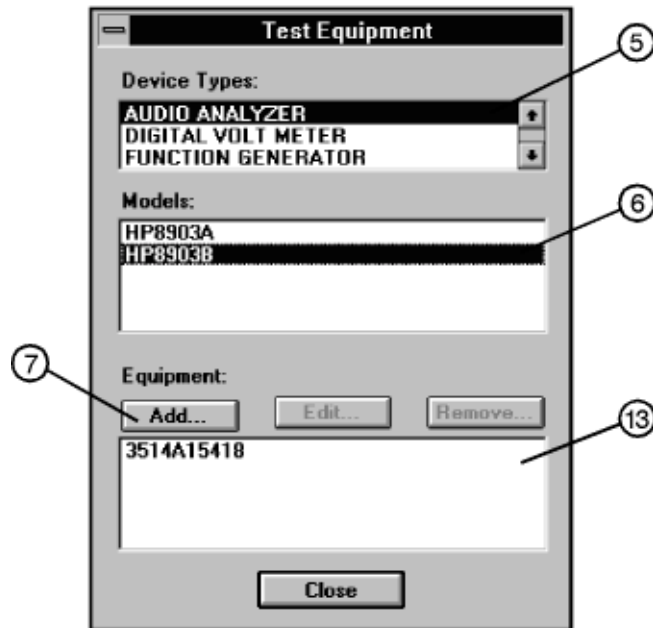

wk797a

**Figure 4-4. Adding Test Equipment Using the Test Equipment Menu**

3. Select the model of the device (item 6).
4. Click **Add** (item 7).
5. In the **New Test Equipment** window (refer to Figure 4-5), enter the following parameters into the appropriate box:

**Serial Number** of the new equipment (item 8).

**HP-IB Address** of the new equipment (item 9). This address must be in the range of 0-31 and it should not conflict with any other instrument address already present in the test setup. NOTE: The power sensor must be assigned HP-IB address -1 (negative 1).

**Cal Due Date** the projected calibration due date of the new equipment (item 10).

**Trace Number** the calibration tracking number (item 11). This is the last required item.

**Calibration Type** (optional) is used only when special calibration data is associated with the device being added, and only as a function setup by the factory for equipment requiring specific calibration data (item 14). The only devices currently requiring this feature are power sensors.

The following Table 4-1, is an example of the calibration information that is required to insure accuracy in measurements using the power sensor. This window is accessed for data entry by selecting the words CAL DATA from the **Calibration Type** field in the **Edit** or **New Test Equipment** window, Figure 4-5.



**Table 4 -1. An Example of Calibration Data for Power Sensors**

Frequency (MHz)	Calibration Factor (%)
.1000	97.6
.3000	98.9
1.0	99.1
3.0	99.4

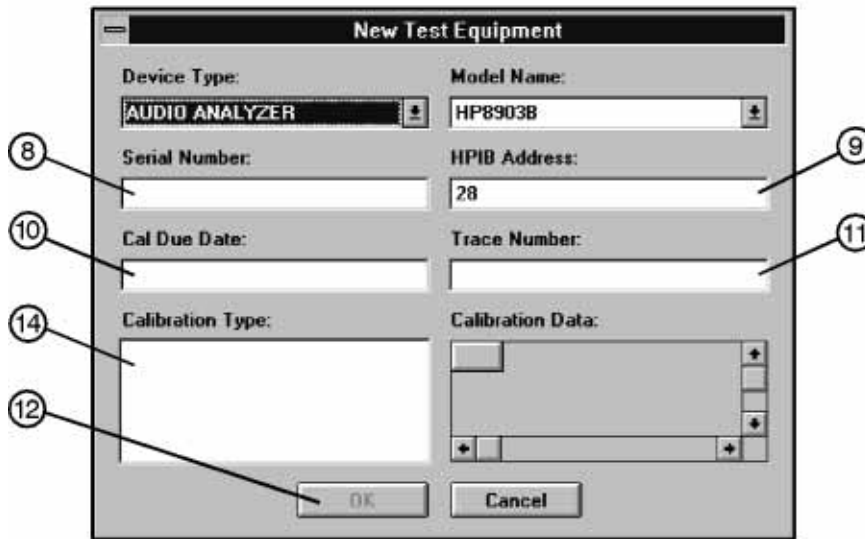

wk798a

**Figure 4-5. Adding the Equipment Information Using the New Test Equipment Window**

6. Click **OK** (item 12). NOTE: The serial number of the test equipment added will be displayed in the **Equipment** field of the **Test Equipment** dialog box (Figure 4-4, item 13).

**Removing Test Equipment**

Removal of test equipment is accomplished using the **Test Equipment** dialog box. Refer to Figure 4-6.

1. Select the **Device Type** of the test equipment to be removed (item 15).

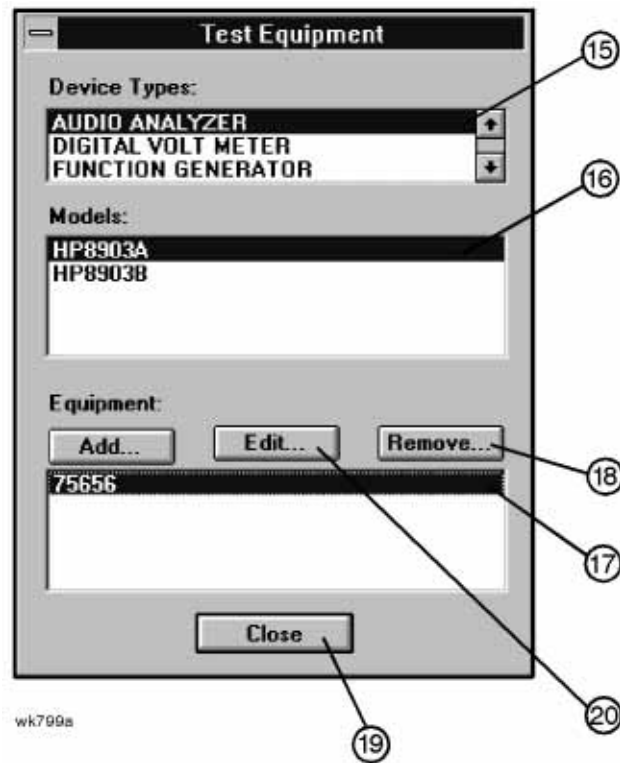

**Figure 4-6. Removing and Editing Test Equipment Using the Test Equipment Window**

2. Select the model of the test equipment to be removed from the **Models** field (item 16).
3. Select the serial number of the test equipment to be removed from the **Equipment** field (item 17).
4. Click **Remove** (item 18).
5. Click **Close** (item 19).

### **Editing Test Equipment**

Editing of test equipment parameters is accomplished using the **Test Equipment** dialog box. Refer to Figure 4-6.

1. Select the **Device Type** of the test equipment to be edited (item 15).
2. Select the model of the test equipment to be edited from the **Models** field (item 16).
3. Select the serial number of the test equipment to be edited (item 17).
4. Click **Edit** (item 20). Change the field parameters as necessary.
5. Click **OK** (Figure 4-5, item 12).

6. Click **Close** (item 19).

### Adding Device Drivers

**CAUTION:**

The following three procedures: Adding/Removing Device (Test Equipment) Drivers, Adding/Removing Test Drivers, and Adding/Removing Datapacks are included for informational purposes. These procedures should only be used when instructions are provided describing which drivers or datapacks need replacement or removal.

Follow these instructions to add test equipment device drivers to the program:

1. The **DUT Selection** window opens by default. It is not necessary to select any device to perform the administrative setup functions.

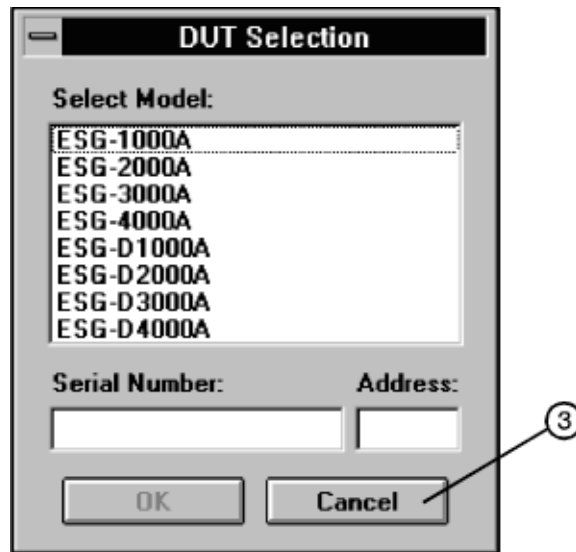

wk768a

**Figure 4-7. The DUT Selection Window**

Click **Cancel** to close the **DUT Selection** window (item 3).

2. Refer to Figure 4-8. In the **File** drop-down menu, select **Test Equipment Drivers** (item 21).

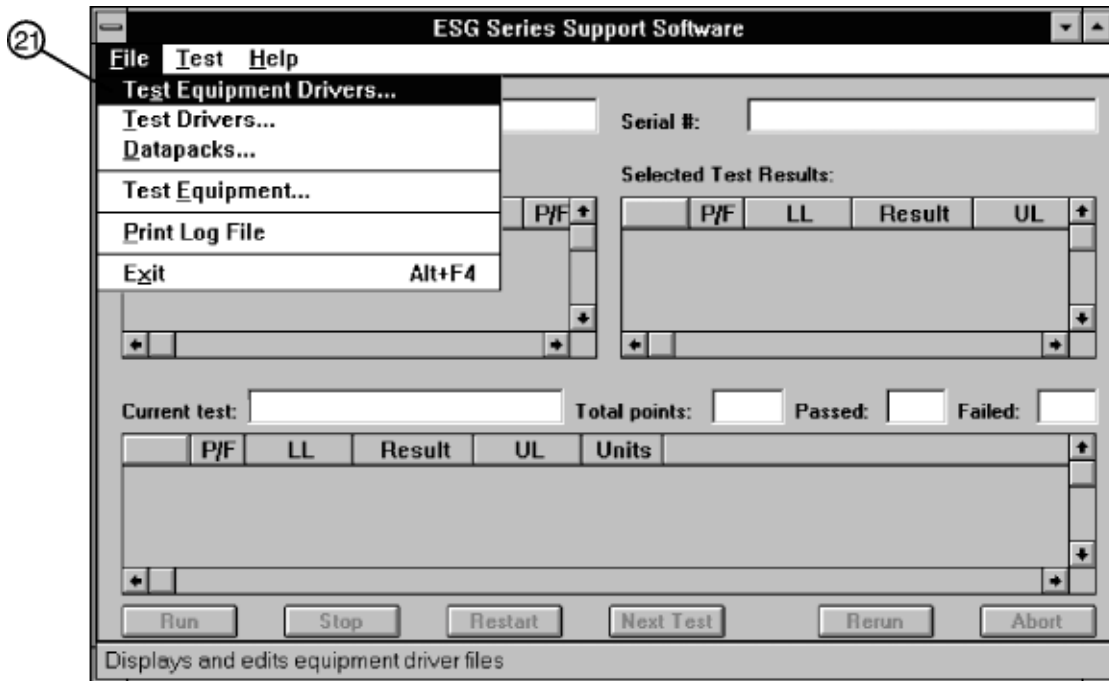

wk764a

**Figure 4-8. Test Equipment Drivers in the File Drop-Down Menu**

This selection allows for the addition or removal of software drivers for the test equipment being used to verify the performance of the DUT.

3. To add a device driver to the existing list of test equipment drivers, click **Add** (Figure 4-9, item 22).

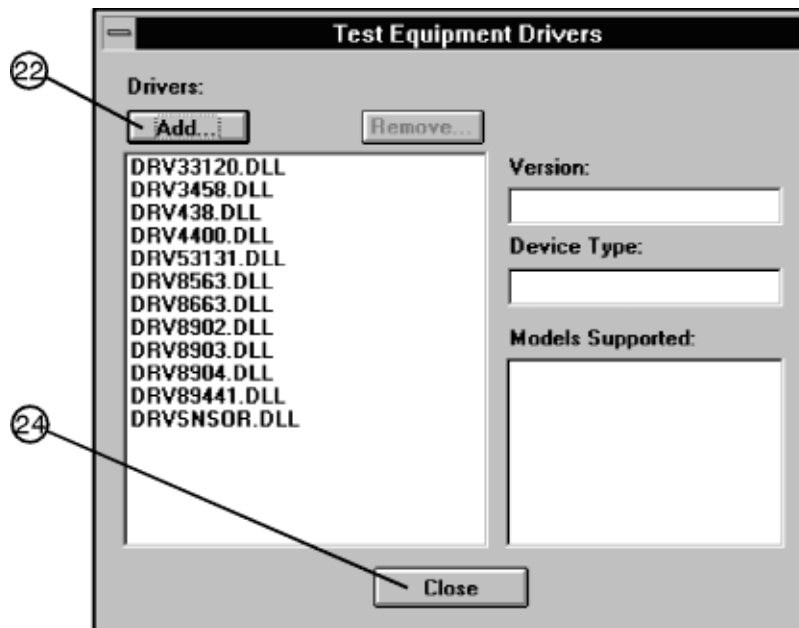

wk765a

Figure 4-9. Adding a Device Driver Using the Test Equipment Drivers Window

4. Refer to Figure 4-10. Using the standard file search procedure, select the driver that you are adding and click **OK** (item 23).



wk767a

Figure 4-10. Using the Open Dialog Box to Search for a Device Driver File to Add

The selected driver should now be displayed in the **Test Equipment Drivers** dialog box, as seen in Figure 4-11.

### Removing Device Drivers

Removal of device drivers is accomplished using the **Test Equipment Drivers** dialog box. Refer to Figure 4-11.

1. Refer to Figure 4-11. Select the driver (.dll) file to be removed (item 26).

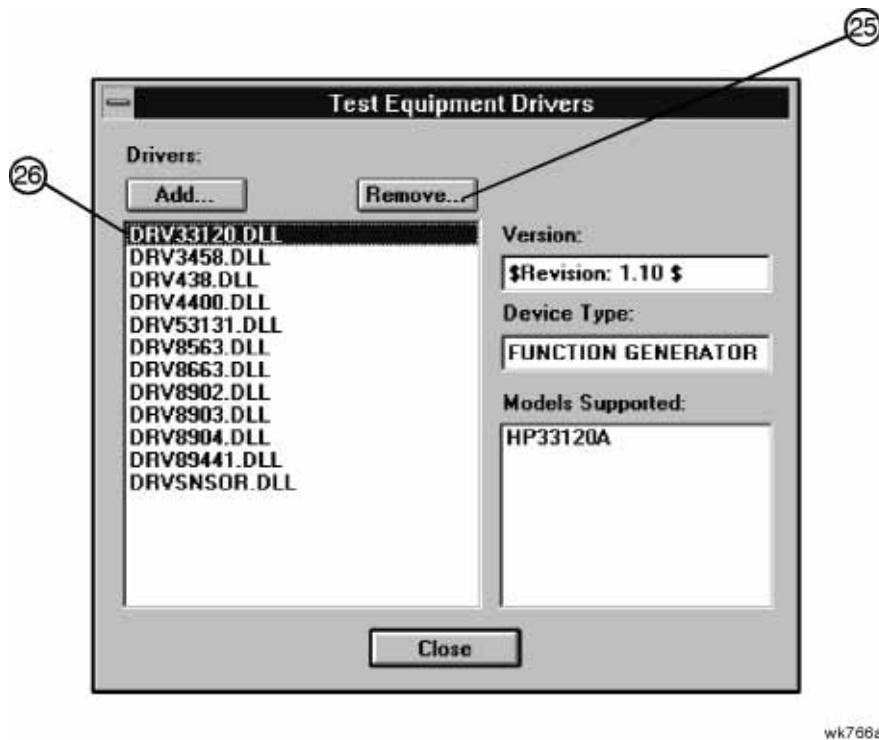

**Figure 4-11. Removing a Device Driver Using the Test Equipment Drivers Window**

2. Insure that the information displayed in the **Version**, **Device Type**, and **Models Supported** fields reflects the current information for the selected driver.
3. Click **Remove** (item 25).
4. Click **Close** (Figure 4-9, item 24).

### Adding Test Drivers

The **Test Drivers** window allows for the addition of software drivers for the test procedures being used to verify the performance of the DUT. Follow these instructions to add a test driver:

1. Refer to Figure 4-12. In the **File** drop-down menu, select **Test Drivers** (item 27).

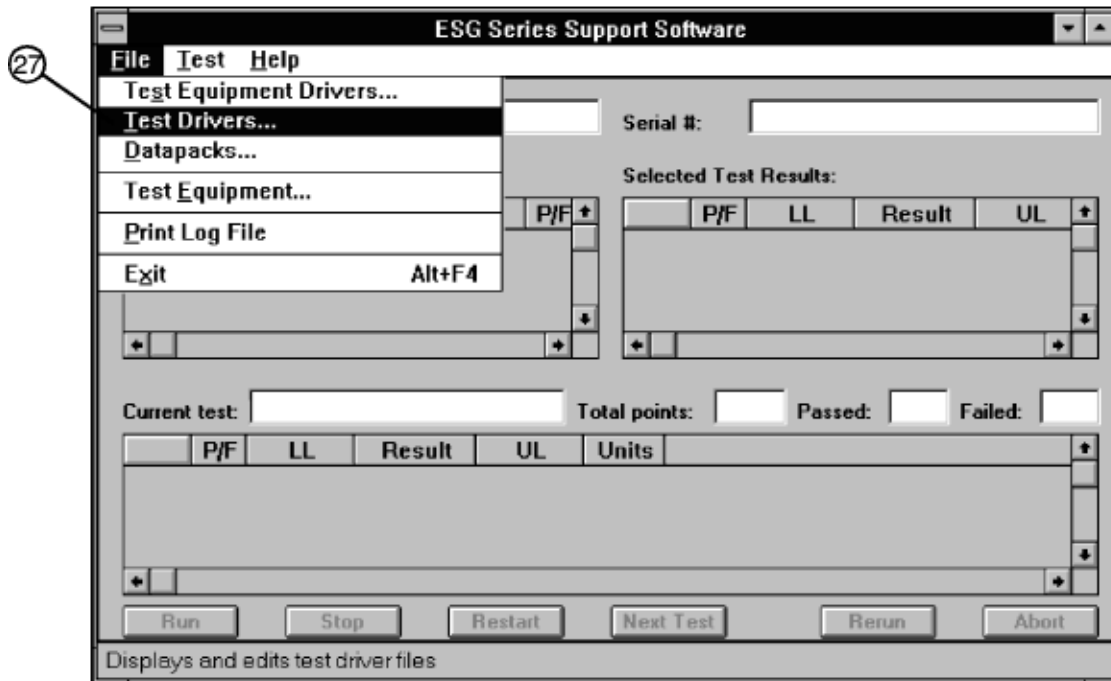

wk792a

**Figure 4-12. Test Drivers in the File Drop-Down Menu**

2. Refer to Figure 4-13. To add a test driver to the existing list of test drivers, click **Add** (item 28).

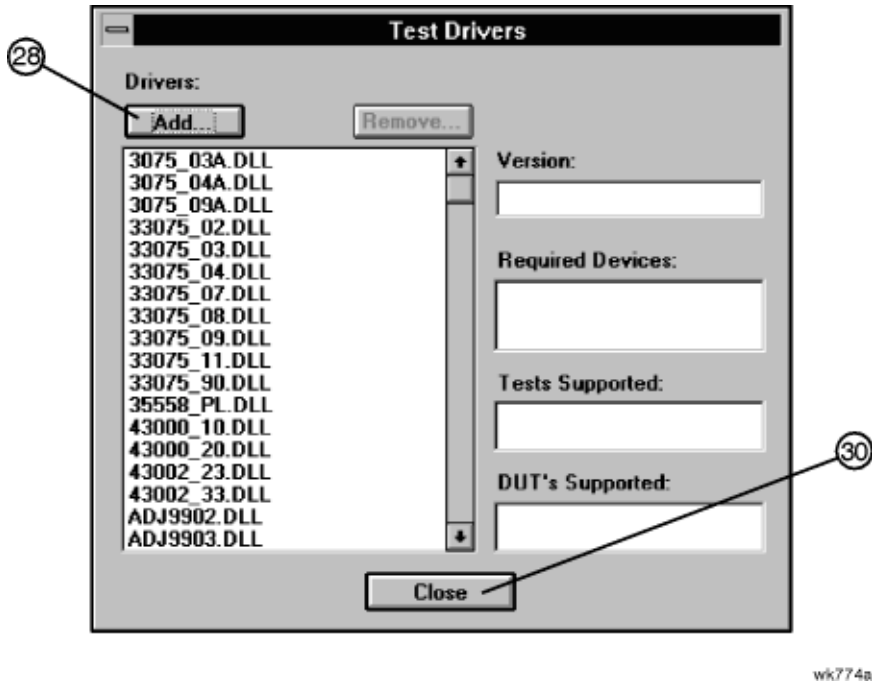

Figure 4-13. Adding a Test Driver Using the Test Drivers Window

3. Refer to Figure 4-14. Using the standard file search procedure, select the test driver that you are adding and click **OK** (item 29).





**Figure 4-14. Using the Open Dialog Box to Search for a Test Driver File to Add**

The selected driver should now be displayed in the **Test Drivers** dialog box, as seen in Figure 4-13.

4. Click **Close** (Figure 4-13, item 30).

### Removing Test Drivers

Removal of test drivers is accomplished using the **Test Drivers** dialog box. Refer to Figure 4-15.

1. Select the driver (**.dll**) file to be removed (item31).

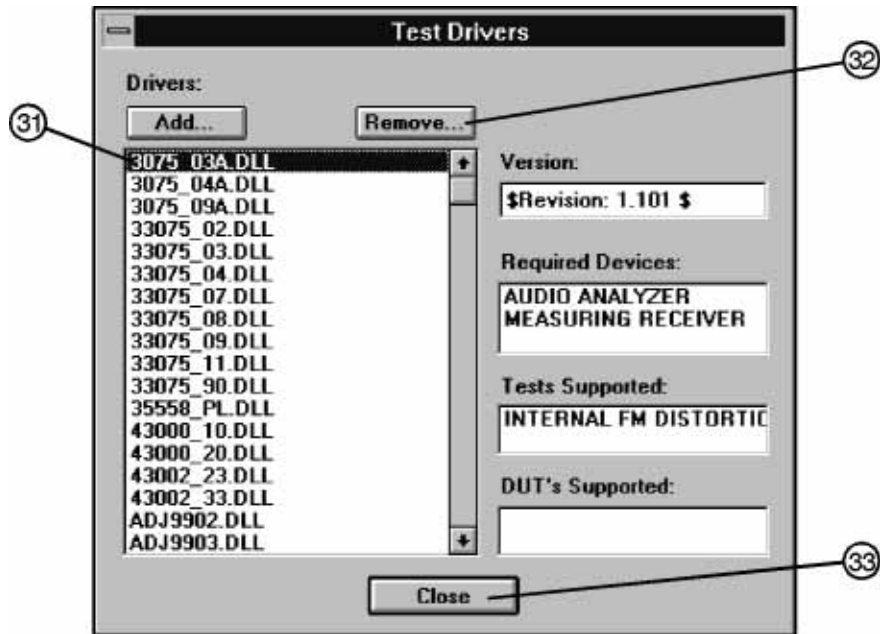

wk775a

**Figure 4-15. Removing a Test Driver Using the Test Drivers Window**

2. Insure that the information displayed in the **Version**, **Device Type**, and **Models Supported** fields reflects the current information for the selected driver.
3. Click **Remove** (item 32).
4. Click **Close** (item 33).

### Adding Datapacks

The addition of datapacks is accomplished using the **Datapacks** dialog box.

The **Datapacks** window allows for the addition of datapacks for the test procedures being used to verify the performance of the DUT. Follow these instructions to add a datapack:

1. Refer to Figure 4-16. In the **File** drop-down menu, select **Datapacks** (item 34).

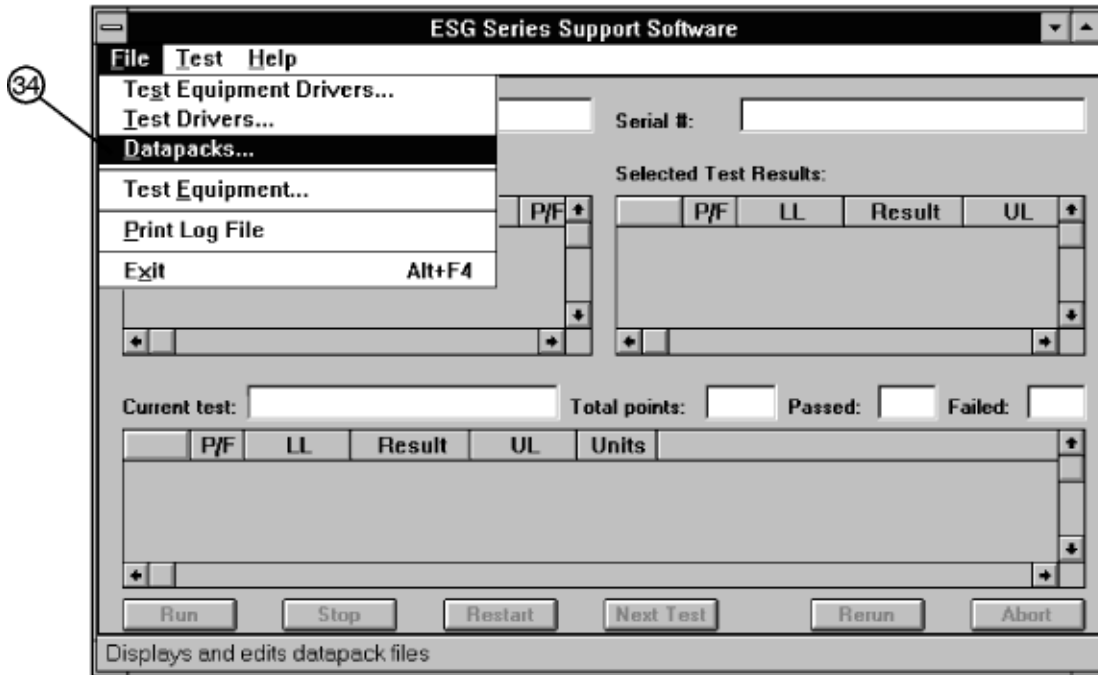

wk793a

Figure 4-16. Datapacks in the File Drop-Down Menu

2. Refer to Figure 4-17. To add a datapack to the existing list of datapacks, click **Add** (item 35).

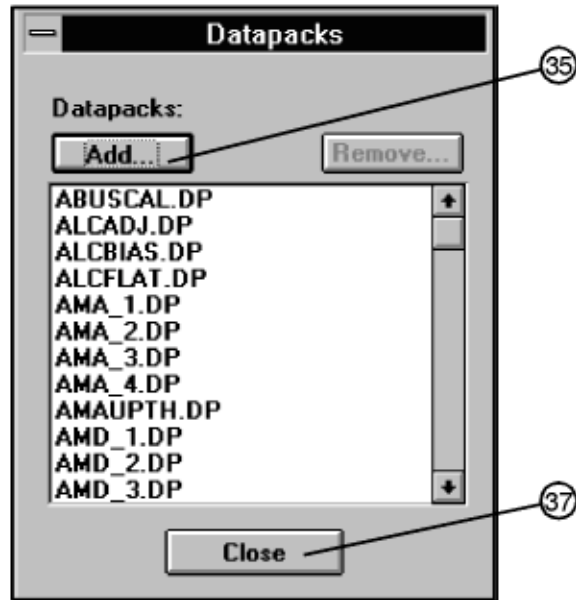

wk794a

Figure 4-17. Adding a Datapack Using the Datapacks Window

3. Refer to Figure 4-18. Using the standard file search procedure, select the datapack that you are adding and click **OK** (item 36).

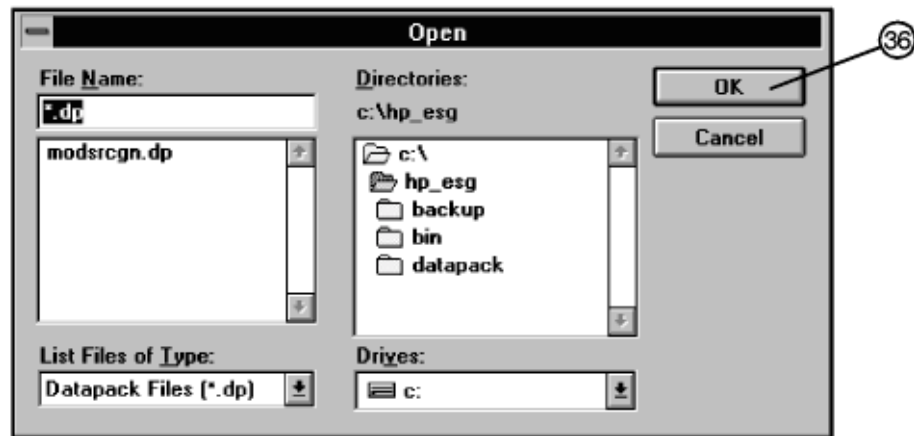

wk795a

Figure 4-18. Using the Open Dialog Box to Search for a Datapack File to Add

The selected driver should now be displayed in the **Datapacks** dialog box, as seen in Figure 4-17.

4. Click **Close** (Figure 4-17, item 37).

### Removing Datapacks

Removal of datapacks is accomplished using the **Datapacks** dialog box. Refer to Figure 4-19.

1. Select the datapack (**.dp**) file to be removed (item 38).

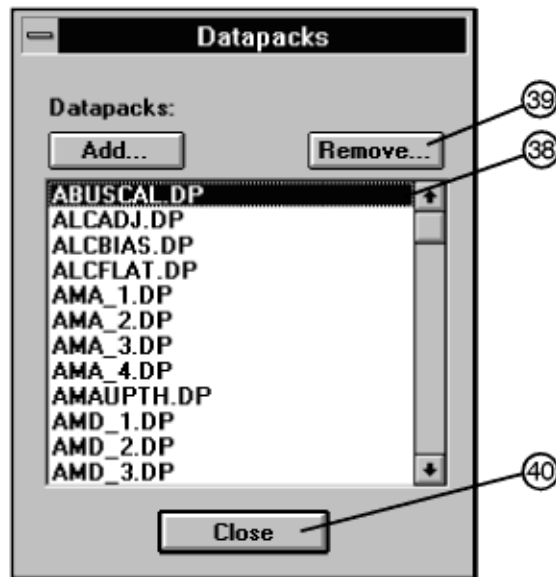

wk796a

**Figure 4-19. Removing a Datapack Using the Datapacks Window**

2. Click **Remove** (item 39).
3. Click **Close** (item 40).

---

## **5 Performance Tests**

**\_\_\_\_\_**  
The procedures in this chapter test the electrical performance of the signal generator to its specifications.

---

## **Calibration Cycle**

This instrument requires periodic verification of performance. Under normal use and environmental conditions, the instrument should be calibrated every two years. Normal use is defined as about 2,000 hours of use per year.

---

## Performance Test Records

Using the “ESG Series Support Software,” you can printout a test record that contains the results of the automated performance tests. For the two manual performance tests: “Timebase Aging Rate” and “Modulation Source Frequency Accuracy;” a performance test record is located at the end of this chapter where you can record the test results.



---

## **Recommended Test Equipment**

The recommended test equipment table, located in Chapter 2, is the complete list of equipment required to perform the procedures in this book. Test equipment is also listed with each test description and test setup. However, to avoid clutter in the figures, the controller that is required to run the support software is not shown in the test setup for each automated test. The controller must be connected through HP-IB to all of the test equipment in the currently selected automated test(s). For performance tests, other equipment can be substituted for the recommended models if it meets or exceeds the critical specifications listed in Table 2-1. For the adjustment procedure, no equipment substitutions are available.

---

## Support Software

The “ESG Series Support Software” runs performance tests and generates reports that document the results of the tests. The following performance tests are manual tests and CANNOT be run with the software:

- Timebase Aging Rate
- Modulation Source Frequency Accuracy

This chapter shows how to run the software to test and verify the performance of a signal generator. “Chapter 4. Service Software” explains how to set up the software for a particular set of test instruments and interfaced components in a test environment.

### Running the Performance Tests

- 1 Load the support software into the personal computer. Refer to “Chapter 4. Service Software” for detailed instructions on installing the software.
- 2 Click on the installed support software icon.
- 3 Fill in the fields in the displayed window:
  - a In the “User Name:” field, type in the word: “User” (item 1).
  - b In the “Password:” field, type in the word: “User” (item 2).
- 4 Click **OK**.

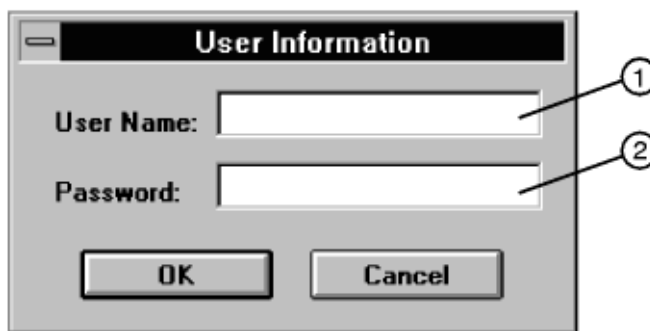

wk758a

**Figure 5-1. Support Software “User Information” Window**

- 5 Select the device under test (DUT):
  - a Click on the model number of the signal generator (DUT) that you will test (item 3).
  - b Click on the “Serial Number:” box, and then type in the serial number of the signal generator (item 4).
  - c Click on the “Address:” box, and then type in the HP-IB address of the signal generator (item 5). You can find the HP-IB address on the signal generator display after you press the following keys: **Utility, HP-IB/RS-232, HP-IB Address.**
- 6 Click **OK**.

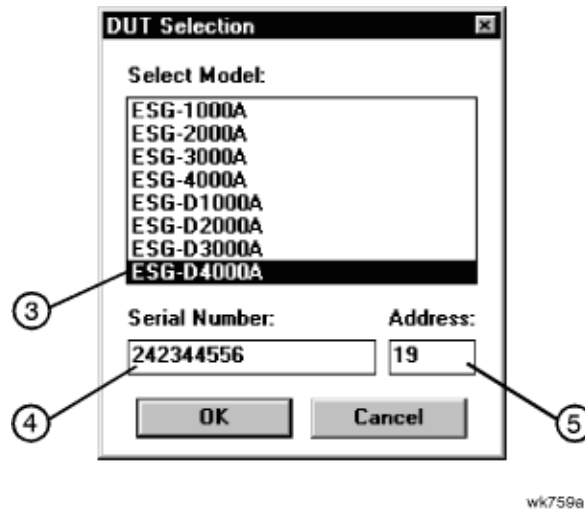

Figure 5-2. Support Software “DUT (Device Under Test) Selection” Window

- 7 Create a list of test equipment that will verify the signal generator’s performance:
  - a Click on a device type (item 6) that you want to add to the equipment list.
  - b Click on the model (item 7) of the device type that you want to add to the equipment list.
  - c Click on the serial number (item 8) of an available instrument. There may be more than one instrument available for any model. Make sure the instrument calibration due date has not passed. If the due date has passed, use another available instrument. Also alert your system administrator that the due date has passed.
  - d Click **Add** (item 9) to add the instrument to the test equipment list.
  - e Continue adding test equipment to the list by repeating this step.

You can correct mistakes while you are entering instruments in the test equipment list:

- To delete a single entry in the equipment list, click on the unwanted selection in the “Selected Test Equipment:” box (item 10) and then click **Remove** (item 11).
- To delete the entire list of equipment, click **Clear** (item 12).

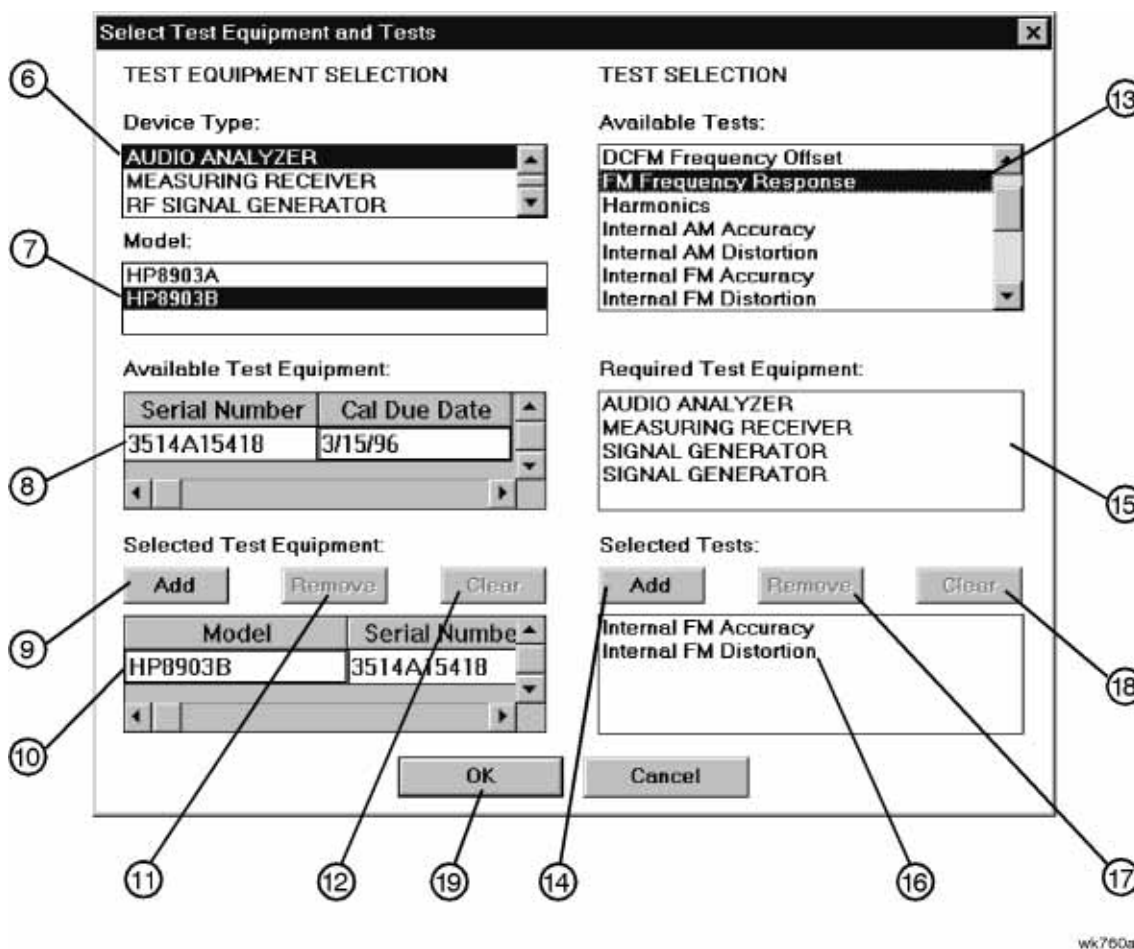
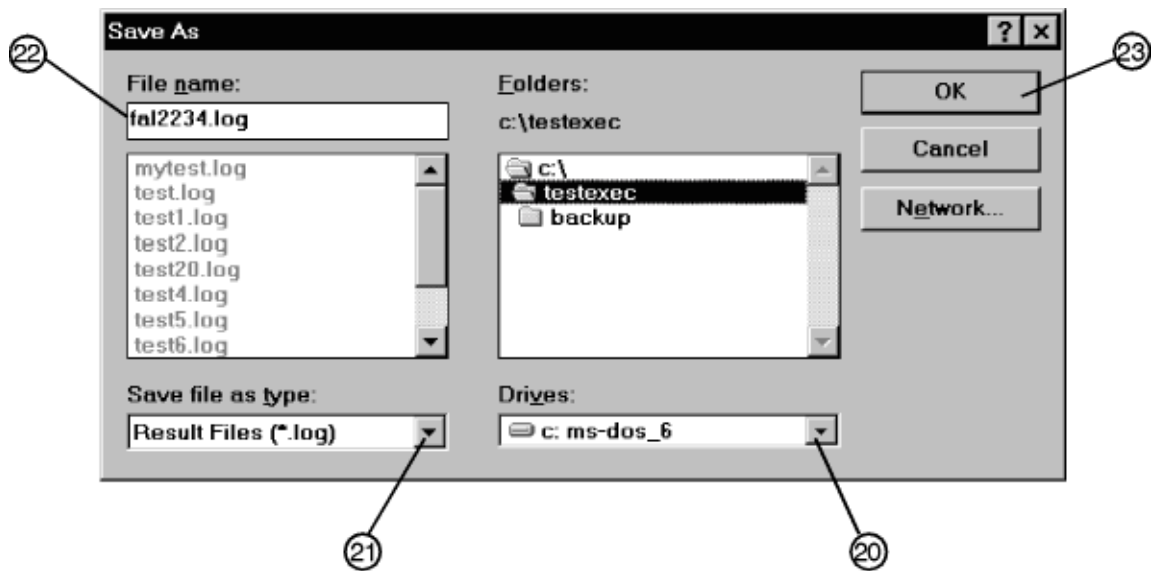

Figure 5-3. Support Software “Select Test Equipment and Tests” Window

- 8 Create a list of performance tests that you want the software to run:
    - a Click on a performance test title (item 13).
    - b Click **Add** (item 14) to add the test to the list of tests that the software will run.

You can view the required test equipment (item 15) for a performance test by clicking on the test title (item 13) in the “Available Tests” box.
  - c Continue adding performance tests to the list by repeating this step.
- You can correct mistakes while you are entering tests in the performance test list:
- To delete a single entry in the test list, click on the unwanted selection in the “Selected Tests:” box (item 16) and then click **Remove** (item 17).
  - To delete the entire list of equipment, click **Clear** (item 18).

- 9 Click **OK** (item 19).
- 10 To save the test results to a file, make the following selections:
  - a Click on the “Drives” window (item 20) and select the drive where you want to save the test results.
  - b Click on the “Save file as type:” window (item 21) and select the file type for saving the test results.
  - c Click on the “File name:” window (item 22) and type in a name for the test results file.
- 11 Click **OK** (item 23).



wk782a

**Figure 5-4. Support Software “Save As” Window**

- 12 Verify that the selected DUT and serial number (item 24) and selected tests (item 25) are correct. Then click **Run**.

The selected performance tests are listed in the order in which they will run. You cannot change this order.

During the testing sequence the window shows the following information:

- The model and serial number of the signal generator under test (item 24).
- The list of selected performance tests, with the current test highlighted (item 25).
- The performance test currently running (item 26).
- The data points taken (item 27).
- The total number of data points that will be measured during the test (item 28).
- The number of points that have currently passed the test (item 29).
- The number of points that have currently failed the test (item 30).
- The lower limits (LL) and upper limits (UL) for each test point (items 31 and 32).
- The measured results (item 33) and the pass/fail (P/F) indication (item 34).

You can scroll the results window, vertically and horizontally. You can also click on the following during the test sequence:

- **Run** starts the test sequence, or continues the test that was running when you clicked **Stop**.
- **Stop** halts the test sequence.
- **Restart** goes to the beginning of the test that was running when you clicked **Stop**.
- **Next Test** jumps to the test that is next in the sequence and continues running the remaining tests.
- **Abort** clears all information from this window. To begin a performance test sequence with a new DUT, click “File” and “New Session.” This allows a reselection of the DUT, equipment list, and performance test list.

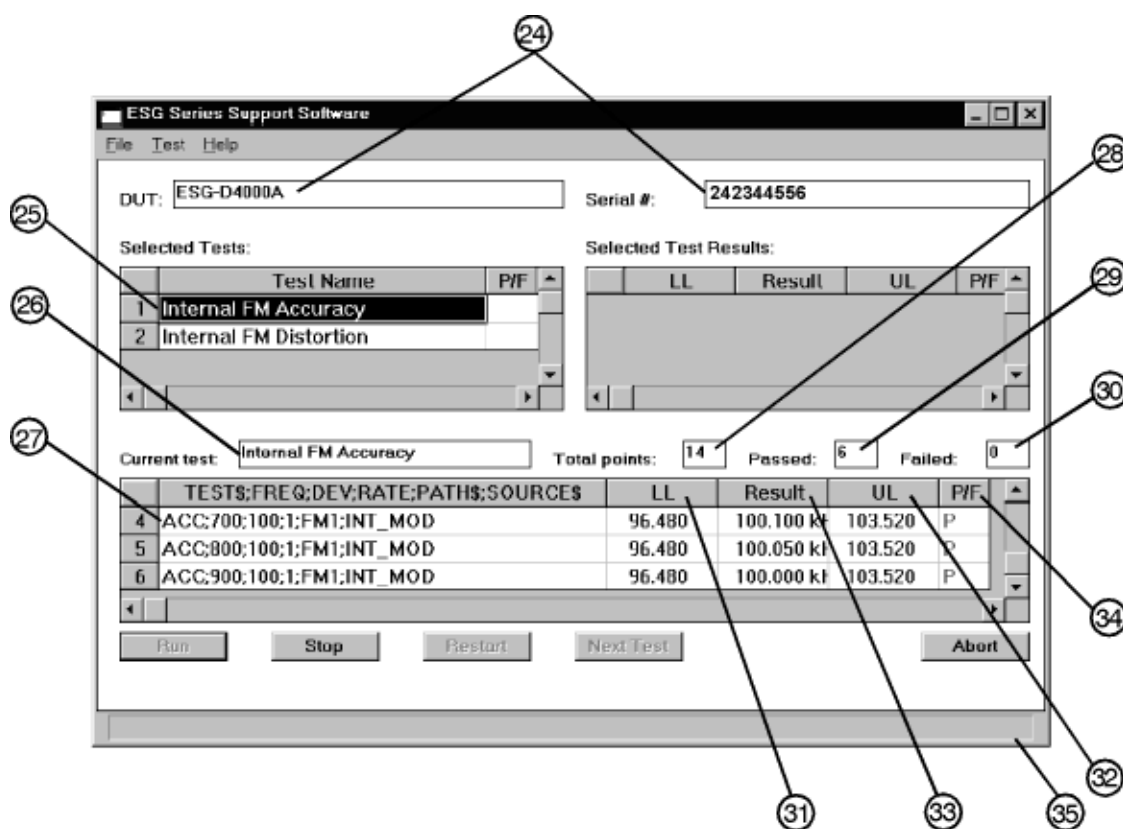

wk781a

Figure 5-5. Support Software “Main Test and Results” Window

- 13 When the software has run all of the selected performance tests, the status bar (item 35) indicates that the tests are completed.

## Printing the Performance Test Results

14. To print all the results of the entire test sequence, click “File” and “Print.”

## **Exiting the Support Software Program**

15. To exit the performance tests program, click “File” and “Exit.”

---

## 1. Internal FM Accuracy and Distortion Performance Tests

These automatic tests verify the FM accuracy and distortion specifications. Accuracy is verified directly with a measuring receiver, and distortion is verified by measuring the demodulated output of the measuring receiver, using the audio analyzer. The audio analyzer provides a more accurate verification with better resolution than just the measuring receiver alone.

### Recommended Equipment

- HP 8902A Measuring Receiver
- HP 8903B Audio Analyzer

### To Set Up the Equipment

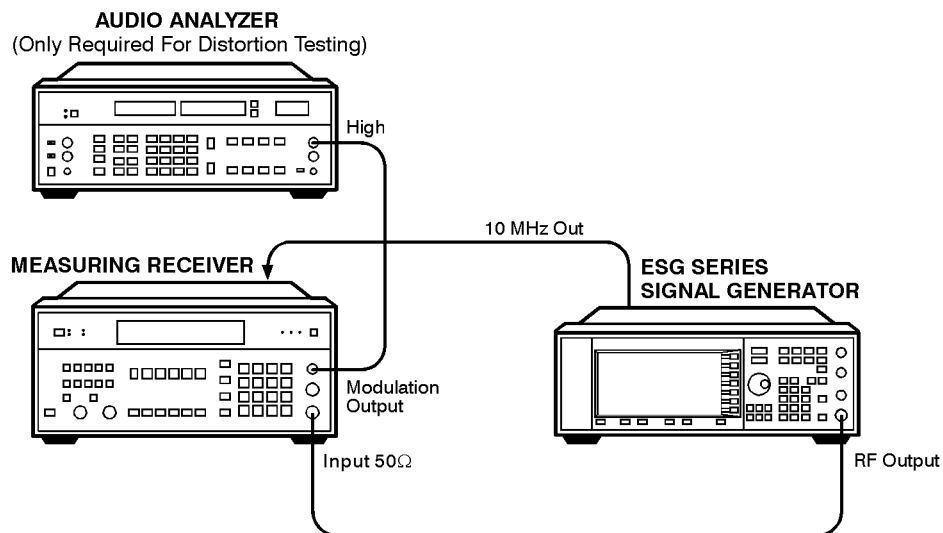

wk721a

Figure 5-6. Test Setup for Internal FM Accuracy and Distortion Performance Tests



---

## 2. Internal AM Accuracy and Distortion Performance Tests

These automatic tests verify the AM accuracy and distortion specifications.

For frequencies at or below 1300 MHz, accuracy is verified directly with a measuring receiver, and distortion is verified by measuring the demodulated output from the measuring receiver with an audio analyzer. The audio analyzer provides a more accurate verification with better resolution than just the measuring receiver alone.

For frequencies above 1300 MHz, the RF output from the signal generator is mixed with the output from another signal generator (local oscillator) to produce a suitable input frequency for the measuring receiver.

For a frequency of 4 GHz, verification is accomplished by covering two different frequency spans through the use of two mixers.

### Recommended Equipment

- HP 8902A Measuring Receiver
- HP 8903A Audio Analyzer
- HP 8663A Signal Generator
- MD/MDC-174 Mixer (1 to 2800 MHz)
- MD/MDC-164 Mixer (0.5 to 9 GHz)

**To Set Up the Equipment for Accuracy/Distortion for AM  $\leq 1300$  MHz**

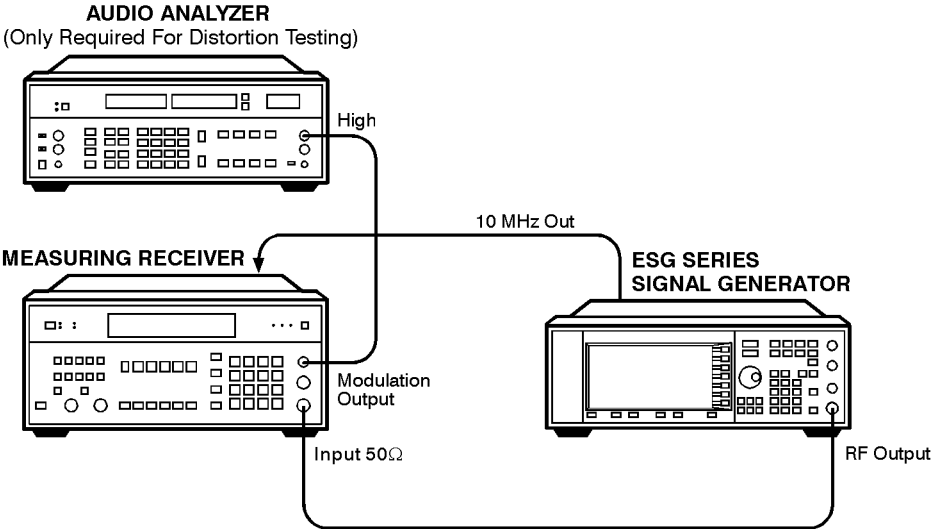

wk721a

**Figure 5-7. Test Setup for Accuracy and Distortion for AM  $\leq 1300$  MHz**

2. Internal AM Accuracy and Distortion Performance Tests

To Set Up the Equipment for Accuracy and Distortion for AM >1300 MHz ≤2500 MHz

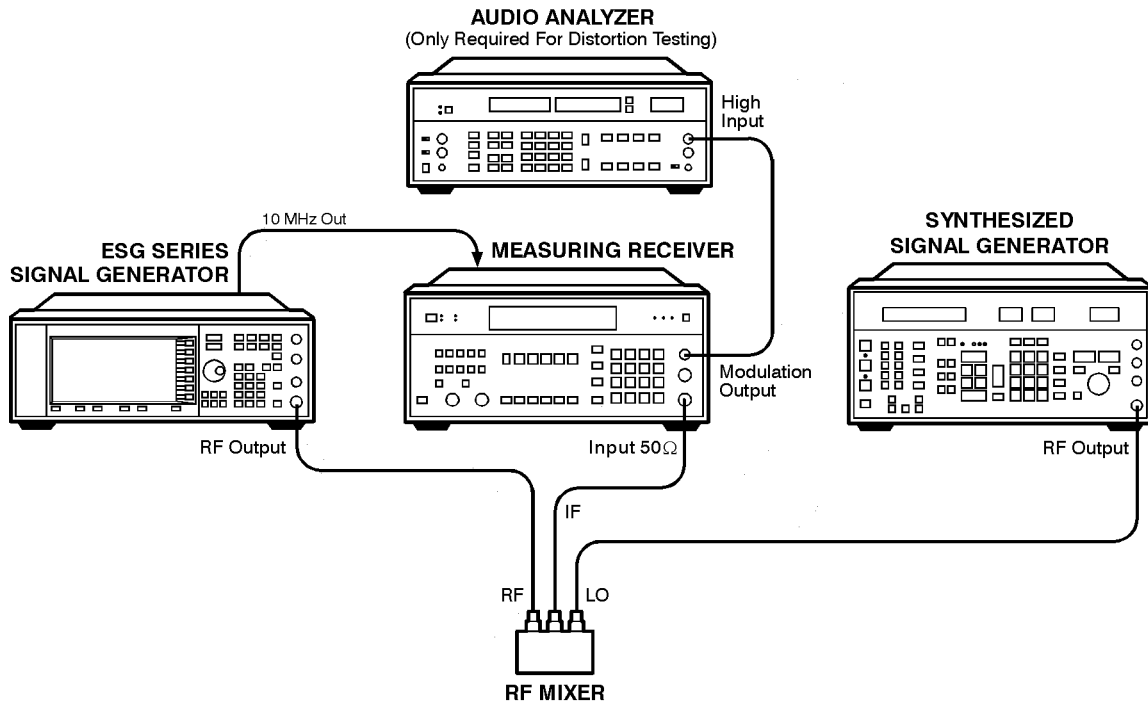

wk718a

Figure 5-8. Test Setup for Accuracy and Distortion for AM >1300 MHz ≤ 2500 MHz

**To Set Up the Equipment for Accuracy and Distortion for AM > 2500 MHz**

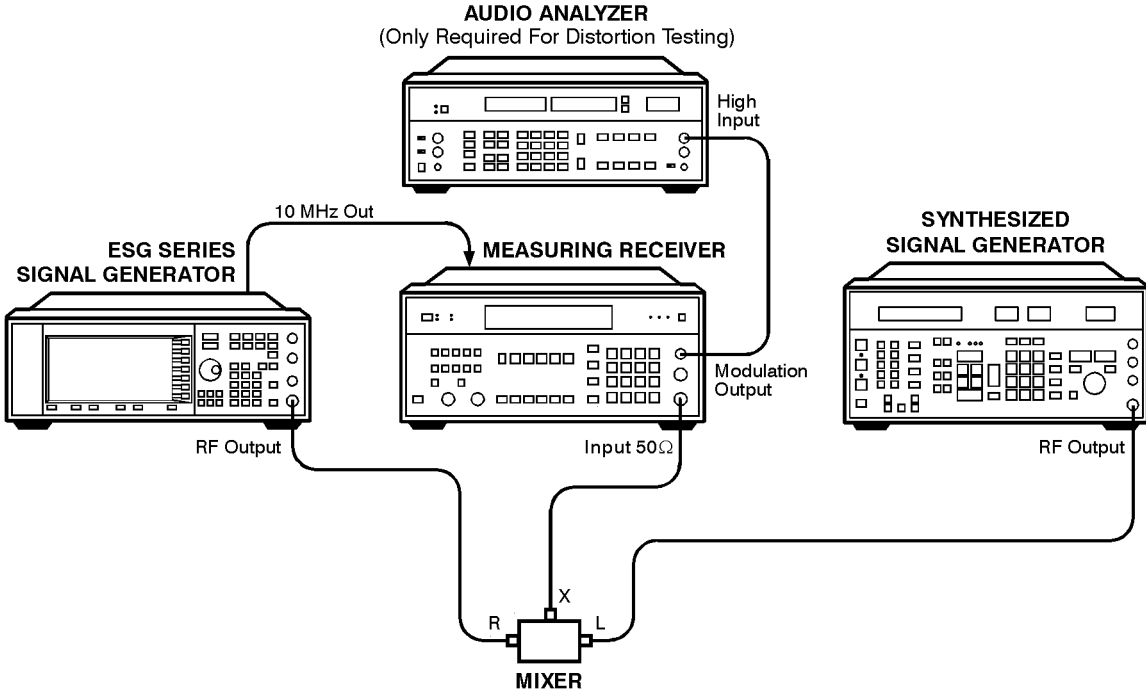

wk725a

**Figure 5-9. Test Setup for Accuracy and Distortion for AM > 2500 MHz**

---

### 3. Phase Modulation Accuracy and Distortion Performance Tests

These automatic tests verify the phase modulation accuracy and distortion specifications. Accuracy is verified directly with a measuring receiver, and distortion is verified by measuring the demodulated output from the measuring receiver, using the audio analyzer. The audio analyzer provides a more accurate verification with better resolution than just the measuring receiver alone.

#### Recommended Equipment

- HP 8902A Measuring Receiver
- HP 8903A Audio Analyzer

#### To Set Up the Equipment

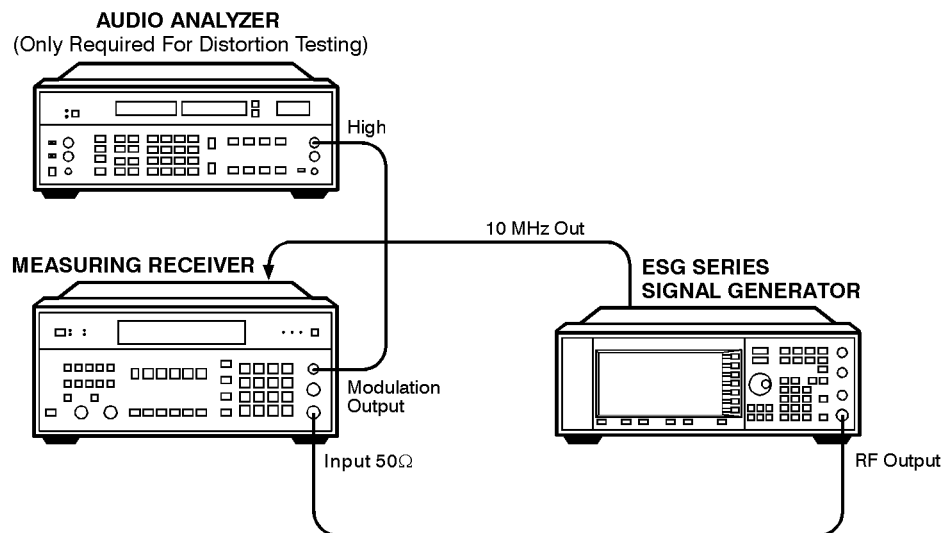

wk721a

Figure 5-10. Test Setup for Accuracy and Distortion for Phase Modulation Performance Tests

---

## 4. FM Frequency Response Performance Test

This automatic test verifies the FM frequency response specifications. The equipment measures the variations in frequency deviations due to changes in the applied FM rate; DC to 100 kHz. The variations are expressed relative to a reference signal; 1 kHz rate set at 100 kHz deviation, in dB. Each frequency is tested with this sequence:

- 1 A reference signal is measured.
- 2 The set deviation is measured for each applied rate change.
- 3 Each deviation measurement is compared to the reference signal deviation.

The comparison is a calculation of the difference in the deviations relative to the reference rate. The relative value is the FM frequency response.

### Recommended Equipment

- HP 8902A Measuring Receiver
- HP 8904A Function Generator

### To Set Up the Equipment

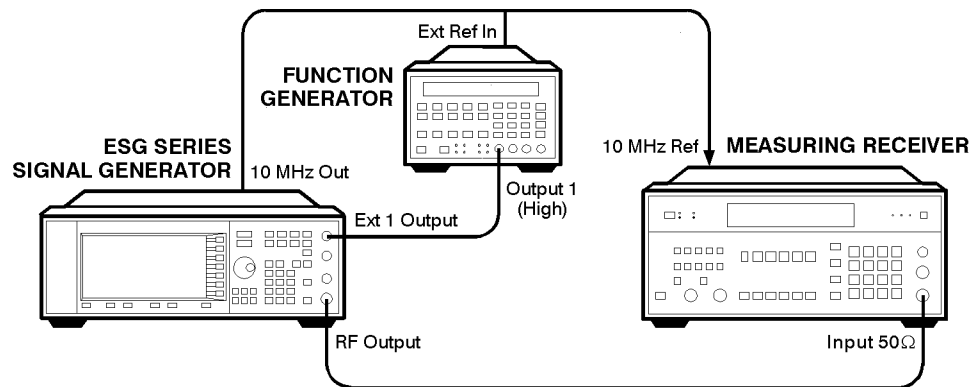

wk728a

Figure 5-11. Test Setup for FM Frequency Response Performance Tests

## 5. AM Frequency Response Performance Test

### 5. AM Frequency Response Performance Test

This automatic test verifies the AM frequency response specifications. The equipment measures the variations in modulation depth due to changes in the applied AM rate; DC to 10 kHz. The response is relative to a 1 kHz rate set at the test depth, and expressed in dB. Each frequency is tested with the following sequence:

- 1 A reference signal is measured.
- 2 The set depth is measured for each applied rate change.
- 3 Each depth measurement is compared to the reference signal depth.

The comparison is a calculation of the difference in the depths relative to the reference rate. The relative value is the AM Frequency Response.

#### Recommended Equipment

- HP 8902A Measuring Receiver
- HP 8904A Function Generator
- HP 8663A Signal Generator
- MD/MDC-164 Mixer (0.5 to 9 GHz)

#### To Set Up the Equipment for Frequency Response for AM $\leq 1300$ MHz

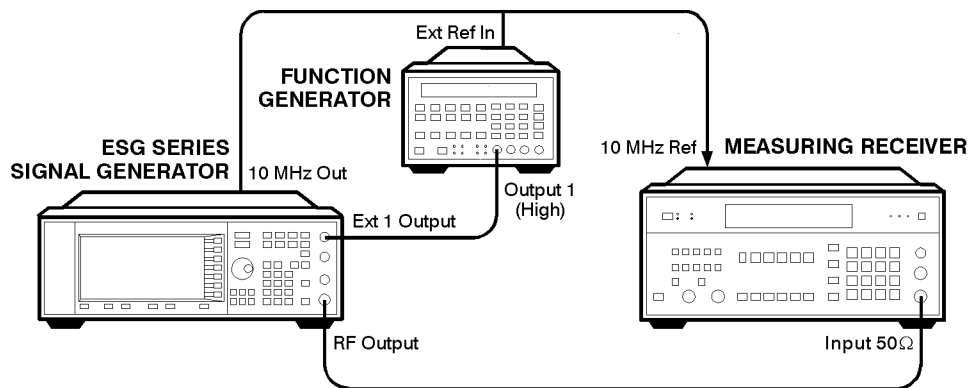

wk728a

Figure 5-12. Test Setup for Frequency Response for AM  $\leq 1300$  MHz

**To Set Up the Equipment for Frequency Response for AM >1300 MHz**

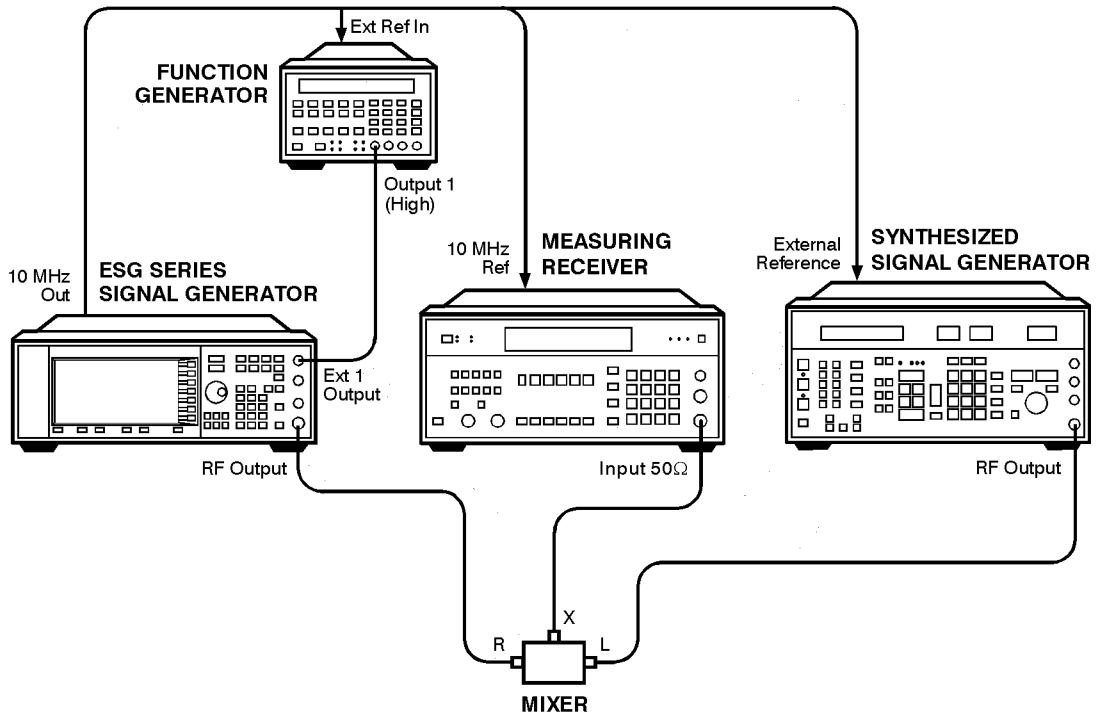

wk730a

**Figure 5-13. Test Setup for Frequency Response for AM >1300 MHz**



## 6. Phase Modulation Frequency Response Performance Test

---

### 6. Phase Modulation Frequency Response Performance Test

This automatic test verifies the phase modulation frequency response specifications. The equipment measures the variations in phase deviations due to changes in the applied PM rate; DC to 100 kHz. The response is relative to a 1 kHz reference at the same phase deviation, and expressed in dB. Each frequency is tested with the following sequence:

- 1 A reference signal is measured.
- 2 The set deviation is measured for each applied rate change.
- 3 Each deviation measurement is compared to the reference signal deviation.

The comparison is a calculation of the difference in the deviations relative to the reference rate. The relative value is the PM frequency response.

#### Recommended Equipment

- HP 8902A Measuring Receiver
- HP 8904A Function Generator

#### To Set Up the Equipment

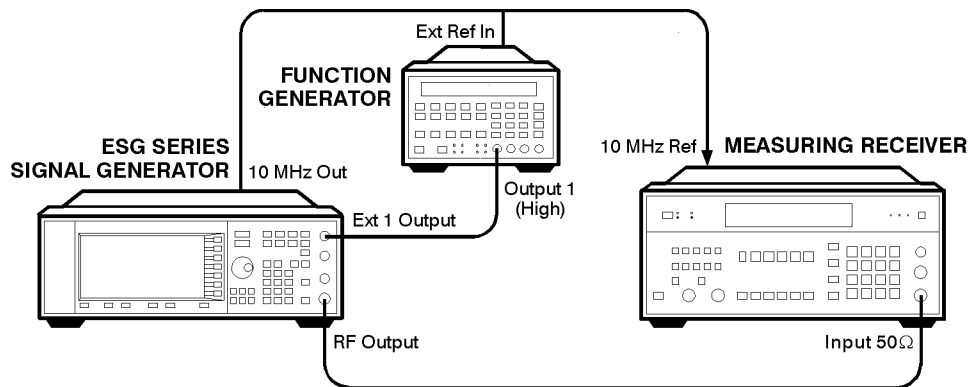

wk728a

**Figure 5-14. Test Setup for Phase Modulation Frequency Response Performance Test**

---

## 7. DCFM Frequency Offset Relative to CW Performance Test

This automatic test verifies the carrier frequency offset, relative to CW. The equipment measures the RF output frequency. For each test point, a comparison is made between a CW reference frequency without DCFM selected, and then with the DCFM selected; the difference is the carrier frequency offset.

### Recommended Equipment

- HP 53132A Frequency Counter
- HP 11667A Splitter

### To Set Up the Equipment for Measurements $\leq 1300$ MHz

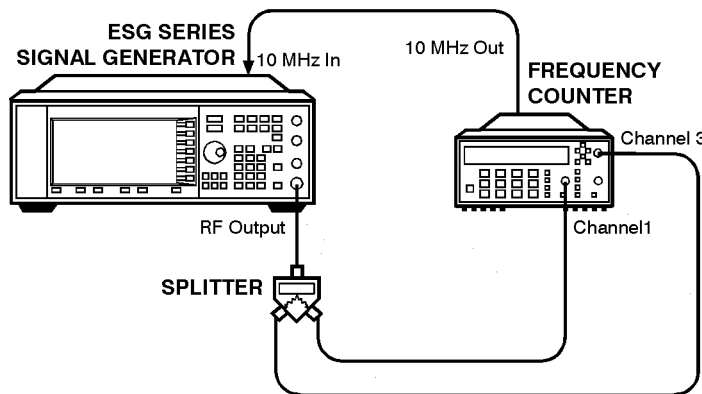

wk727a

Figure 5-15. Test Setup for DC FM Frequency Offset Performance Test

---

## 8. Residual FM Performance Test

This automatic test verifies the residual frequency modulation (FM) specification. The signal generator's RF output signal is mixed with a signal from a low noise external LO. The resultant IF signal is demodulated as it passes through the measuring receiver, bypassing the measuring receiver's internal mixer which is inherently more noisy. Then the audio analyzer measures the demodulated audio signal for an RMS voltage. The measurement is scaled and displayed as RMS mV, but read as residual FM in Hz.

### Recommended Equipment

- HP 8902A Measuring Receiver
- HP 8903B Audio Analyzer
- HP 8663A Signal Generator
- MD/MDC-174 Mixer (1 to 2800 MHz)
- MD/MDC-164 Mixer (0.5 to 9 GHz)

**To Set Up the Equipment for Frequencies  $\leq 2500$  MHz**

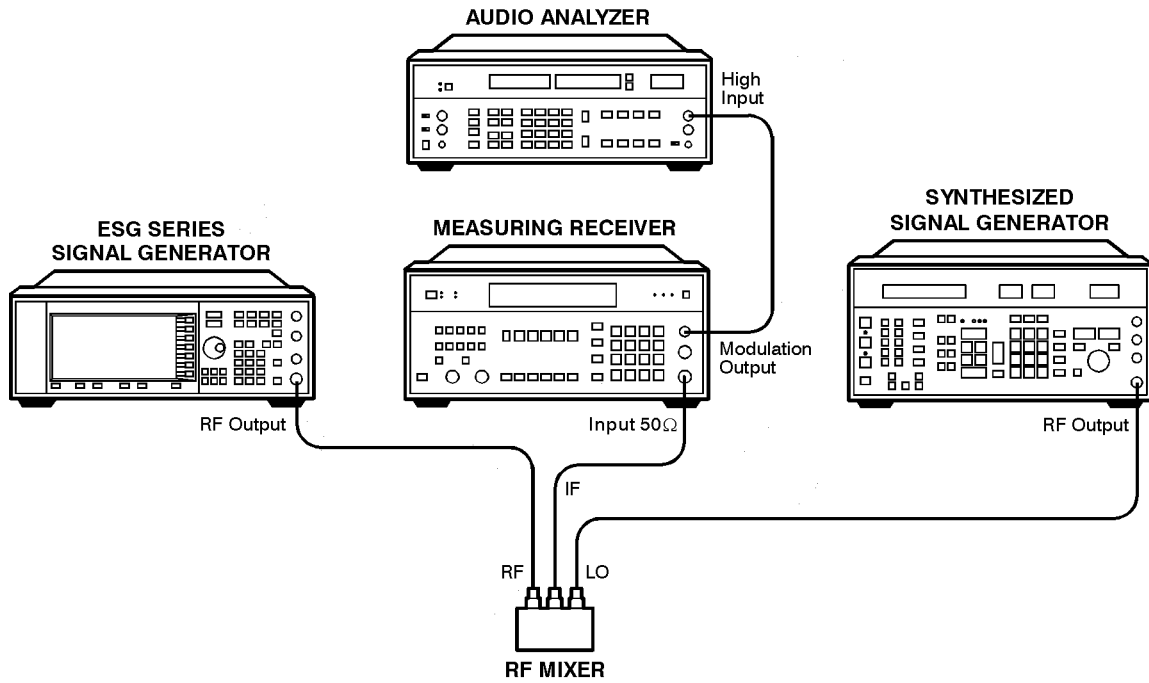

wk738a

**Figure 5-16. Test Setup for Residual FM  $\leq 2500$  MHz**

8. Residual FM Performance Test

To Set Up the Equipment for Frequencies >2500 MHz

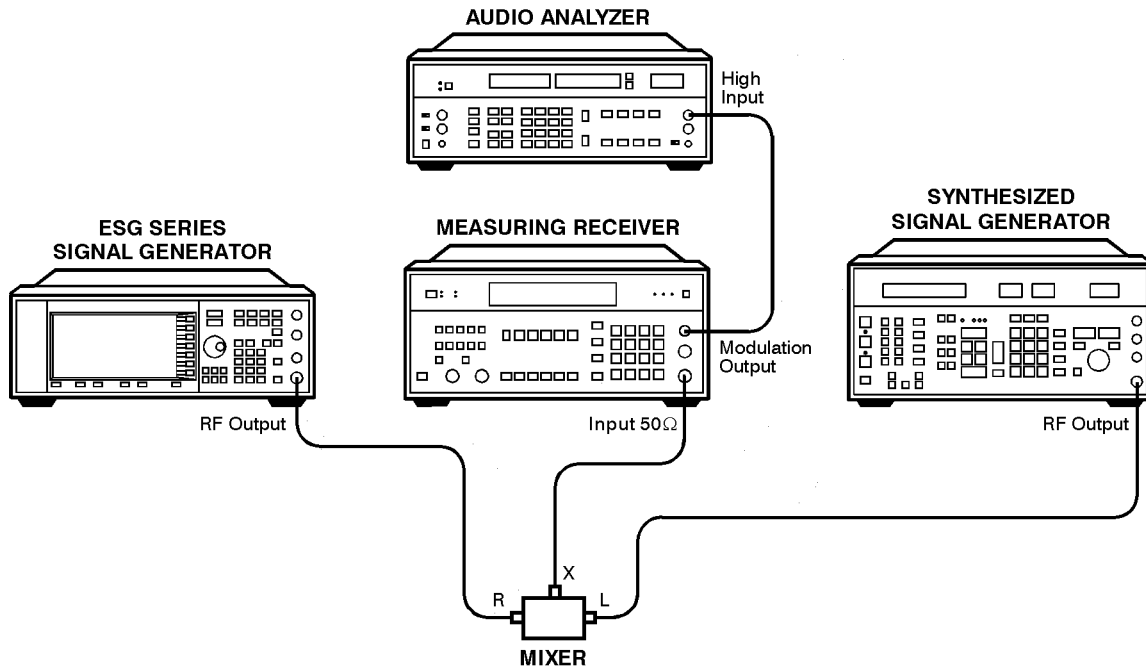

wk740a

Figure 5-17. Test Setup for Residual FM >2500 MHz

---

## 9. Harmonic, Subharmonic, and Nonharmonic Spurious Signals Performance Tests

These automatic tests verify that the harmonic, subharmonic, and nonharmonic spurious signals are within specifications. The signal generator's output signal is set to values where harmonic and spurious signal performance problems are most likely to occur. Then the spectrum analyzer checks the level of the various harmonic and spurious signals and compares each measurement to a signal of known frequency and amplitude.

### Recommended Equipment

- HP 8563E Spectrum Analyzer
- HP 8491B Option 010 Attenuator (10 dB)

### To Set Up the Equipment

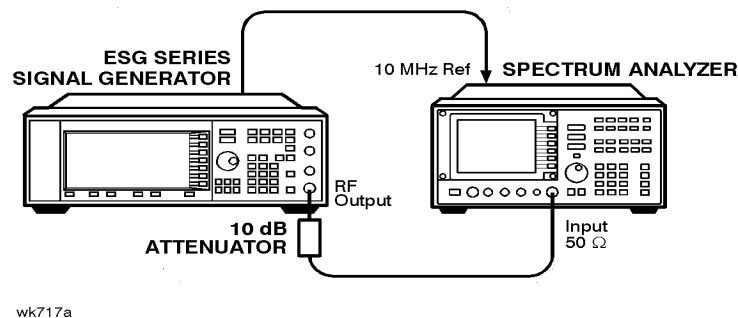

Figure 5-18. Test Setup for Harmonic, Subharmonic, and Nonharmonic Spurious Signals Performance Tests

---

## 10. Power Level Accuracy Performance Test

Conducting this check provides a high level of confidence and a verification that the signal generator's power level circuitry is functioning correctly. The check does not test the signal generator to warranted specifications. Test limits are degraded to take into account measurement uncertainties involved with commercially available test equipment. To have the signal generator tested to warranted specifications, a complete power level accuracy performance test is required. Contact your nearest HP service center for information concerning calibration. The accuracy is measured over the full frequency and power level range of the signal generator.

For power levels  $\geq -10$  dBm, a power meter makes the measurement. A reference is set at  $-10$  dBm for comparisons to subsequent power measurements.

For power levels  $< -10$  dBm and  $> -70$  dBm, a spectrum analyzer makes the measurement. With  $-10$  dBm RF output from the signal generator, a reference of  $0$  dB is set on the spectrum analyzer. The marker delta function measures the relative power level down to  $-70$  dBm. The absolute power level is calculated by summing the power meter measurement at  $-10$  dBm with the relative spectrum analyzer measurement.

For power levels  $< -70$  dBm, an amplifier is inserted between the signal generator and spectrum analyzer, ensuring the signal level is kept well above the spectrum analyzer noise floor. A new reference is set at  $-70$  dBm and the marker delta function measures relative power down to  $-127$  dBm. Again the absolute power level is calculated by summing the power meter measurement at  $-10$  dBm with the relative spectrum analyzer measurement.

For power levels  $< -95$  dBm, the spectrum analyzer uses video averaging to minimize effects of random noise in the measurement system.

---

**NOTE:** Power level measurements are made at extremely low power levels. Results may be affected by unrelated low level signals picked up by the measurement receiver. These could be the result of RF leakage within the device under test or external signals that are at the same tested frequencies. To protect against errors at low power levels, take the following precautions:

- Use a semi-rigid cable between the  $6$  dB attenuator and the spectrum analyzer. Connect the  $6$  dB attenuator directly to the spectrum analyzer. Make sure all the connections are tight. Inspect the cable for any deterioration or cracks.
- Position the signal generator and spectrum analyzer side-by-side and at least  $30$  cm apart, minimizing the possibility of RF leakage. Do NOT position the two instruments with the front panels or rear panels facing each other.
- If RF leakage is suspected, move the signal generator and spectrum analyzer further apart. If the problem is RF leakage between the instruments, the measurement should change with changes in orientation between the two instruments. If the problem is RF leakage inside the device under test, then changes in equipment orientation will have no effect.

### Recommended Equipment

- HP 438A Power Meter
- HP 8482A Power Sensor
- HP 8563E Spectrum Analyzer
- HP 8491A/B Option 006 Attenuator (6 dB)
- HP 8447F Option 010 Preamplifier-Amplifier
- HP 8449B Preamplifier

### To Set Up the Equipment for High Power Level Accuracy

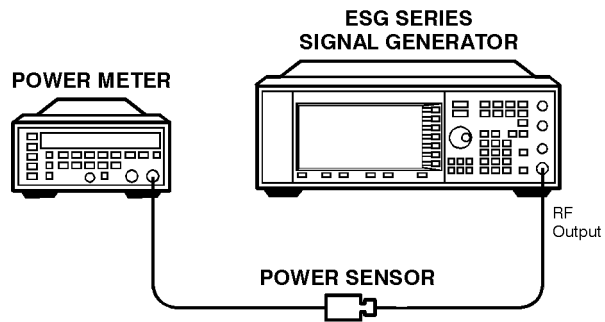

wk716a

Figure 5-19. Test Setup for Power Level Accuracy Performance Test



10. Power Level Accuracy Performance Test

To Set Up the Equipment for High Power Level Accuracy for Levels  $-10$  to  $-70$  dBm

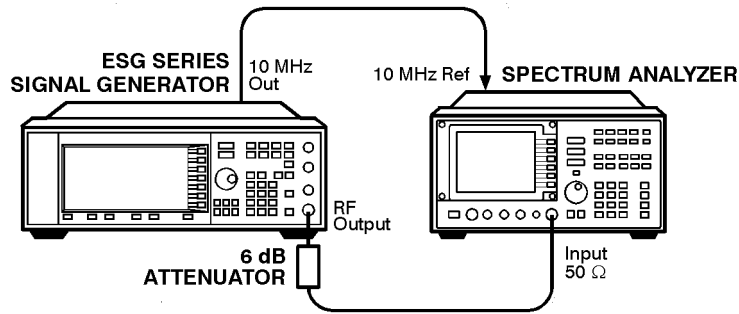

wk742a

Figure 5-20. Test Setup for Power Levels of  $-10$  to  $-70$  dBm

Power Level Accuracy for Power Levels  $<-70$  dBm and  $\leq 1300$  MHz

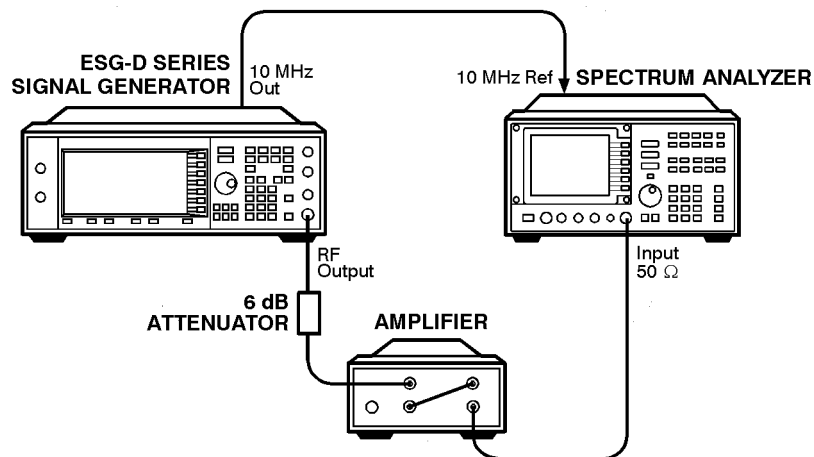

wk745a

Figure 5-21. Test Setup for Power Level Accuracy for Power Levels  $<-70$  dBm and  $\leq 1300$  MHz

**Power Level Accuracy for Power Levels  $< -70$  dBm and  $> 1300$  MHz**

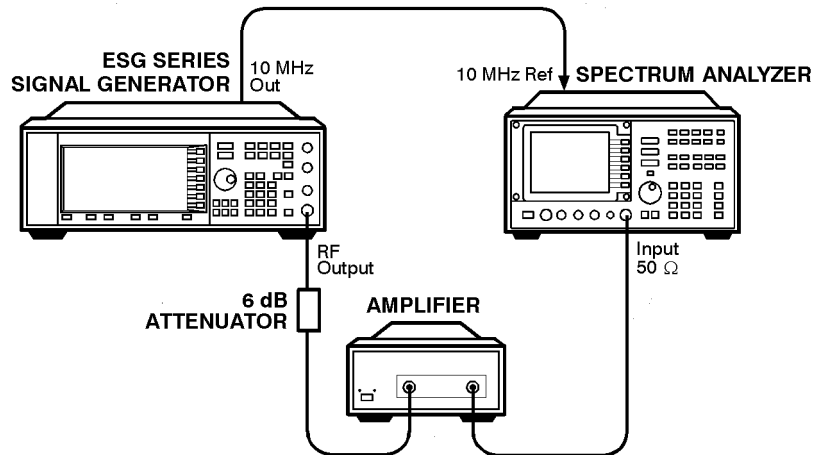

wk755a

**Figure 5-22. Test Setup for Power Level Accuracy for Power Levels  $< -70$  dBm and  $> 1300$  MHz**

---

## 11. Timebase Aging Rate Performance Test: Option 1E5 ONLY

This manual test verifies the accuracy of the signal generator's internal timebase. The time required for a 360° phase change is measured both before and after a specified waiting period. The aging rate is inversely proportional to the absolute value of the difference in the measured times.

The overall accuracy of the internal timebase is a function of:

$TBC \pm AR \pm TE \pm LE$  where:

TBC = timebase calibration

TE = temperature effects

AR = aging rate

LE = line effects

After the timebase is adjusted, the timebase frequency should stay within the aging rate for the following situations:

- The timebase oven does not cool down.
- The instrument keeps the same orientation, with respect to the earth's magnetic field.
- The instrument stays at the same altitude.
- The instrument does not receive any mechanical shock.

If the timebase oven cools (the instrument power switch is set to off), you may have to readjust the timebase frequency after a new warm-up cycle. Typically, however, the timebase frequency returns to within  $\pm 1$  Hz of the original frequency.

---

**NOTE:** The internal timebase can be tested after the AC power is reconnected for 10 minutes. Yet, for best accuracy, test again after the instrument is on for 24 hours.

---

Frequency changes due to either a change in orientation, with respect to the earth's magnetic field, or to a change in altitude usually go away when the instrument is returned to its original position. A frequency change due to mechanical shock usually appears as a fixed frequency error.

### Recommended Equipment

- HP 54610B Digital Oscilloscope
- HP 5071A Primary Frequency Standard

## To Set Up the Equipment

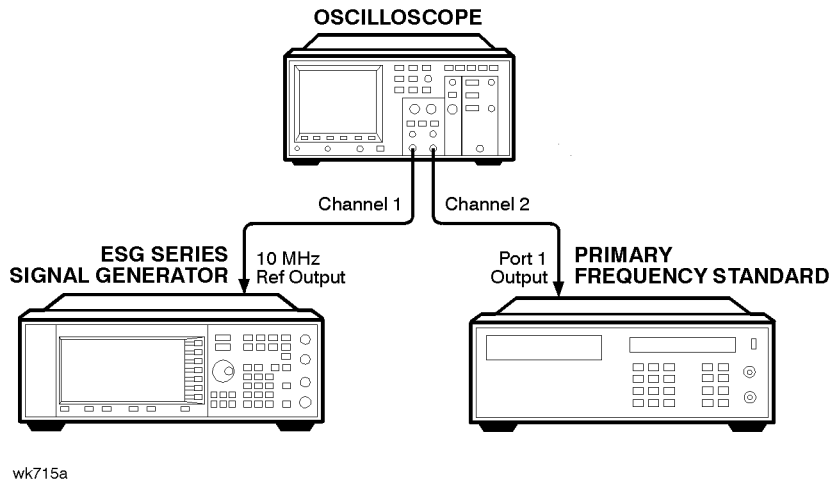

Figure 5-23. Test Setup for Timebase Aging Rate Performance Test

## To Perform the Test

- 1 Preset all instruments and let them warm up for at least one hour.
- 2 If the oscilloscope does not have a 50 $\Omega$  input impedance, connect channel 1 through a 50 $\Omega$  feedthrough.
- 3 On the oscilloscope, adjust the external triggering for a display of the 10 MHz REF OUTPUT signal from the synthesizer.
  - a On Channel 1 of the oscilloscope, set the following:
    - Display: On
    - Volts/Division: 500 mV
    - Input Coupling: DC
    - Input Impedance: 50 ohms (or use a 50 ohm feedthrough)
  - b On Channel 2 of the oscilloscope, set the following:
    - Display: Off
    - Input Coupling: DC
    - Input Impedance: 50 ohms (or use a 50 ohm feedthrough)
  - c On the Timebase of the oscilloscope, set the following:
    - Time/Division: 5 ns
  - d On the Trigger of the oscilloscope, set the following:
    - Trigger Source: CH 2
    - Trigger Mode: Normal
    - Trigger Level: 0V
- 4 If the signal drifts a full cycle (360 $^\circ$ ) in less than 2 minutes, refer to Chapter 6 and perform the “Internal Reference Oscillator Adjustment.” After the adjustment, restart this performance test.
- 5 Watch the oscilloscope display and monitor the time. Notice the time required for a 360 $^\circ$  phase change and record this time as T1.

## 11. Timebase Aging Rate Performance Test: Option 1E5 ONLY

- 6 Wait 3 to 24 hours. Record the time that you waited as T2.
- 7 Repeat steps 1 through 6. Notice the time required for a 360° phase change and record this time as T3.
- 8 Calculate the aging rate as follows:  
Aging Rate = (1 cycle/10 MHz) (1/T1 – 1/T3) (24 hours/T2)  
Example:  
T1 = 351 seconds  
T2 = 3 hours  
T3 = 349 seconds  
= (1 cycle/10 MHz) (1/351s – 1/349s) (24h/3h)  
 $1.306 \times 10^{-11}$  per day
- 9 Write the test results on the performance test record located at the end of this chapter. Compare the results to the limits in the test record.

---

**NOTE:** If the absolute frequency of the standard and the timebase oscillator are extremely close, you can reduce the measurement time (T1 and T3) by measuring the time required for a phase change of less than 360°. In step 4, change 1 cycle to 0.5 cycle for 180°, or 0.25 cycle for 90°.

---

## 12. Pulse Modulation On/Off Ratio Performance Test

This automatic test verifies the pulse modulation on/off ratio. The signal generator is configured for an external pulse input. The spectrum analyzer measures the RF output power with and without the external pulse applied. The power difference is the on/off ratio.

### Recommended Equipment

- HP 8663E Spectrum Analyzer
- HP 8491A/B Option 010 Attenuator (10 dB)
- HP 33120A Arbitrary Waveform Generator

### To Set Up the Equipment

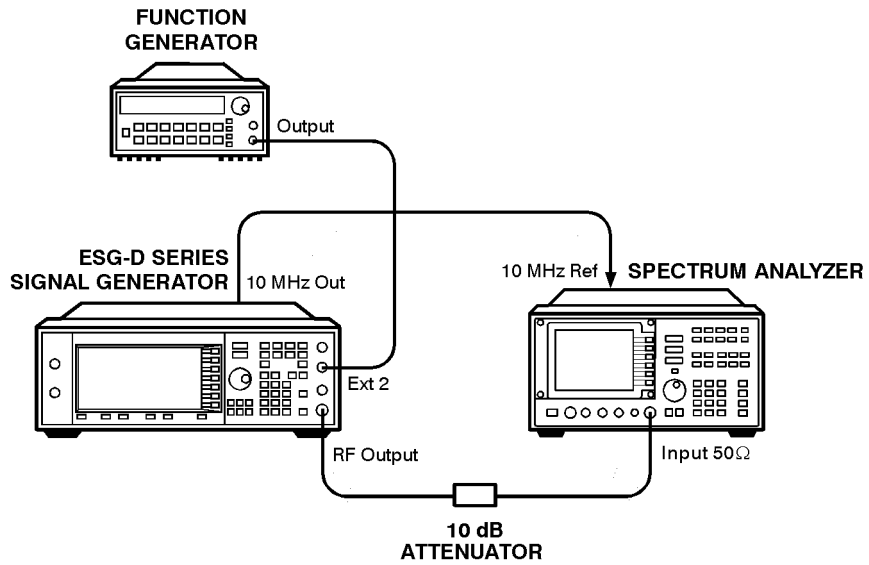

wk747a

Figure 5-24. Test Setup for Pulse Modulation On/Off Ratio Performance Test

---

## 13. Modulation Source Frequency Accuracy Performance Test

This manual test verifies the signal generator's modulation capability at the highest frequency output.

### Recommended Equipment

- HP 5350B Frequency Counter

### To Set Up the Equipment

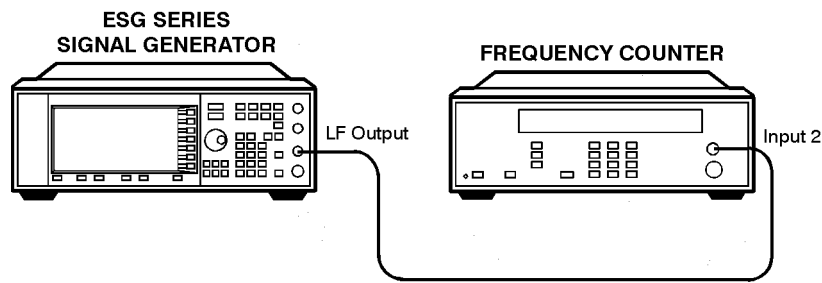

wk732a

Figure 5-25. Test Setup for Modulation Source Frequency Accuracy Performance Test

### To Perform the Procedure

- 1 Preset the test equipment.
- 2 Configure the signal generator as follows:
  - Select **AM**.
  - Press **AM On, AM Rate, 5, 0, kHz**.
  - Press **LF Out, LF Out Amplitude, 1, V**.
- 3 Configure the frequency counter as follows:
  - Press **RESET**.
  - Select 1 Meg Ohms (INPUT 2).
  - Press **HIGH RESOLUTION**.
- 4 View the value that is displayed on the frequency counter. Write this value on the performance test record that is located at the end of this chapter.

---

## Performance Test Records

A performance test record for the two manual tests: “Timebase Aging Rate” and “Modulation Source Frequency Accuracy,” is located next in this chapter. Keep these copies as masters and use a photocopy for each calibration.

Using the “ESG Series Support Software,” you can printout a test record that contains the results of the automated performance tests.



Performance Tests  
**Performance Test Records**

**Table 5-26. HP ESG Series Performance Test Record**

Model _____	Report Number _____		Date _____
Test Equipment Used	Model Number	Trace Number	Cal Due Date
1. Digital Oscilloscope	_____	_____	_____
2. Measuring Receiver	_____	_____	_____
3. Audio Analyzer	_____	_____	_____
4. Signal Generator	_____	_____	_____
5. Mixer 1-2800 MHz	_____	_____	_____
6. Mixer 0.5 -9 GHz	_____	_____	_____
7. Function Generator	_____	_____	_____
8. Signal Generator	_____	_____	_____
9. Mixer (0.5 to 9 GHz)	_____	_____	_____
10. Mixer (.001 to 2.8 GHz)	_____	_____	_____
11. Frequency Counter	_____	_____	_____
12. Power Splitter	_____	_____	_____
13. Spectrum Analyzer	_____	_____	_____
14. Attenuator (10 dB)	_____	_____	_____
15. Attenuator (6 dB)	_____	_____	_____
16. Power Sensor	_____	_____	_____
17. Power Meter	_____	_____	_____
18. Preamplifier-Amplifier	_____	_____	_____
19. Preamplifier	_____	_____	_____
20. Primary Frequency Standard	_____	_____	_____
21. Vector Signal Analyzer	_____	_____	_____
22. Arbitrary Waveform Generator	_____	_____	_____
23. _____	_____	_____	_____

**Table 5-27. HP ESG Series Performance Test Record**

<b>Model:</b> _____	<b>Report Number:</b> _____			<b>Date:</b> _____
<b>Test Description</b>	<b>Minimum Specification</b>	<b>Results</b>	<b>Maximum Specification</b>	<b>Measurement Uncertainty</b>
Timebase Aging Rate: Option 1E5 ONLY		_____	< ±0.0005 ppm/day	$5.6 \times 10^{-11}$ per day
Modulation Source Frequency Accuracy	49,997.5 kHz	_____	50,002.2 kHz	



---

## **6 Adjustments**

**\_\_\_\_\_**  
This chapter contains the adjustment procedures that may be required for the signal generator.

---

## Adjustment Relationships

Anytime an adjustment is made to the signal generator other related adjustments may be affected. For optimal performance, whenever an adjustment is performed, the related adjustments should also be performed.

### Analog Bus Related Adjustments

The following adjustments are optimized if the Analog Bus ADC Calibration has been run recently:

- VCO Bias Potentiometer Adjustment
- FM Inverting Amplifier Offset Calibration
- ALC Modulation Drive Bias Calibration
- VBLO Mixer Bias Calibration
- Level Meter Calibration

### Synthesizer Potentiometer Related Adjustments

The Lock Angle potentiometer is preset fully counter-clockwise in the VCO Bias Adjustment. Both adjustments should always be performed together.

- VCO Bias Potentiometer Adjustment
- Lock Angle Adjustment

### FM Accuracy Related Adjustments

- KV versus Frequency Calibration
- FM Scale DAC Offset Adjustment
- FM Path Offset Adjustment
- FM In-Band DAC Offset Adjustment
- FM Inverting Amplifier Offset Calibration
- FM 1/2 Path Ratio Adjustment
- Modulation Source Relative Gain Calibration
- FM Out-of-Band Calibration
- FM Delay Potentiometer Adjustment
- DCFM Calibration

### AM Accuracy Related Adjustments

- AM Audio Path Offset Calibration
- AM Gain Calibration

### **Burst Modulation Accuracy Related Adjustments**

- Burst Modulator Calibration
- Burst Audio Path Gain Calibration

### **Power Level Range and Accuracy Related Adjustments**

- Prelevel Calibration
- Gain Adjustment
- ALC Modulation Driver Bias Calibration
- VBLO Mixer Bias Calibration
- ALC Calibration
- Power Flatness Calibration
- Attenuator Calibration (Power Meter)
- Level Meter Calibration
- ALC Modulation Flatness Calibration

---

## Internal Reference Oscillator Adjustment

Use this procedure to adjust the internal reference DACs (Digital-to-Analog Convertors). The internal reference oscillator is adjusted with two DACs, one for coarse tuning and one for fine tuning. Using the two DACs, the internal reference oscillator can be adjusted to the resolution of the frequency counter used.

This is a manual adjustment. An automated version of this adjustment is also provided.

### Required Test Equipment

- HP 53132A Universal Counter
- HP 5071A Primary Frequency Standard

### Procedure

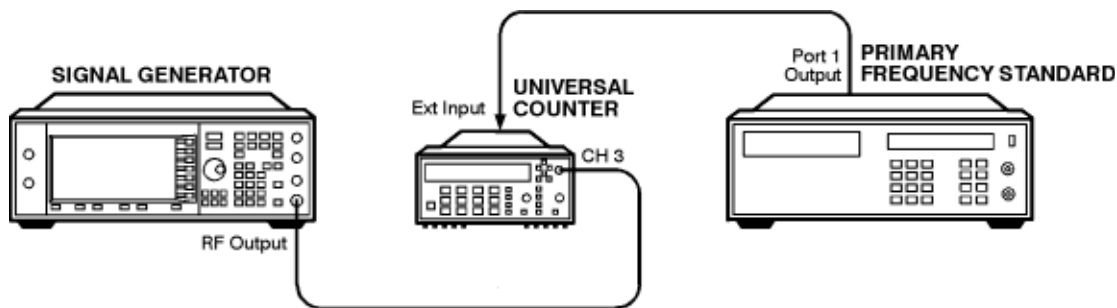

wk7101a

1. Connect the equipment as shown above.
2. Preset all of the equipment.
3. Set the universal counter input to 50Ω.
4. On the signal generator, press the following keys:  
**Preset, Amplitude, 0, dBm, RF ON/OFF**  
**Utility, Instrument Adjustments, Reference Oscillator Adjustment, Ref Osc Fine**
5. Center the fine tuning DAC setting for a value of 128.
6. Press **Ref Osc Coarse** on the signal generator.
7. Adjust the coarse tuning DAC setting for a universal counter reading of 100 MHz.

8. Press **Ref Osc Fine** and adjust the fine tuning DAC setting for a frequency counter reading of 100 MHz, within 0.1 Hz resolution.
9. After adjusting both of the DAC settings, press **Store Ref Osc Setting, Confirm Store**.



---

## Analog Bus ADC Calibration

### Description

This test is used to calibrate the gain of the ABUS. The ABUS is connected to the ground node (ACOM) and the ADC is zeroed. The ABUS is then connected to the 10V reference and measured. The result of the measured value divided by the ideal value is the ABUS gain calibration constant. This value is then saved in the instrument's firmware.

### Required Test Equipment

- HP 3458A Digital Voltmeter

### Procedure

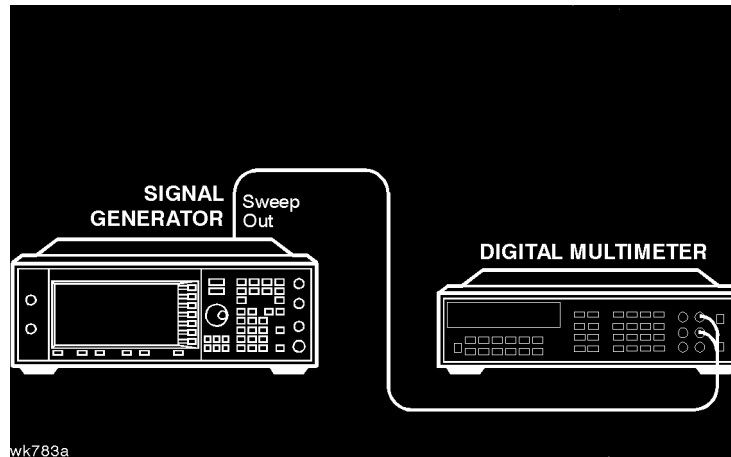

1. Connect the equipment as shown above.
2. Preset all of the equipment.
3. Follow the instructions as they appear on the controller's display.

---

## Internal Source Calibration

### Description

This test is used to calibrate the internal source amplitude versus frequency. The values for offset and gain are set to their default values in the internal source calibration arrays. Next, the offset calibration factor is determined by connecting the DVM to the ABUS and measuring the DC offset of the motherboard common ground ABUS node and the offset of the DSP ABUS node with the DSP set to 0Vdc; the calibration factor is the difference between these two measurements. The scaling factors are determined by setting the DSP to output a full-scale sine wave with the DVM connected to the front panel LF OUTPUT port. Measurements are then made in 1 kHz steps and the calibration factors are calculated to achieve 2 V<sub>peak</sub> on the motherboard by accounting for the nominal gain presented by the reference board. Upon completion, the calibration factors are stored in the instrument's firmware.

### Required Test Equipment

- HP 3458A Digital Voltmeter

### Procedure

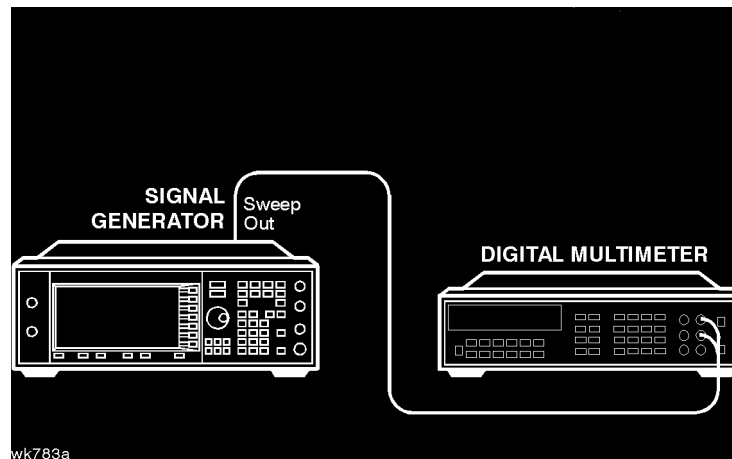

1. Connect the equipment as shown above.
2. Preset all of the equipment.
3. Follow the instructions as they appear on the controller's display.

---

## VCO Bias Potentiometer Adjustment

### Description

This test sets the VCO bias potentiometer at a level that will keep the VCO in a stable operating region over the entire frequency and temperature range. First, the F/2 and the lock angle potentiometers are set fully CW (clock-wise). The instrument is set to 750 MHz and the pot is adjusted until the F/2 oscillations disappear. The voltage at the SYNTH\_F2 ABUS node is measured and then the potentiometer is adjusted for a .77 to .80 V drop.

After you have performed this adjustment, you must perform the Lock Angle Potentiometer Adjustment on the following page.

### Required Test Equipment

- HP 8563E Spectrum Analyzer

### Procedure

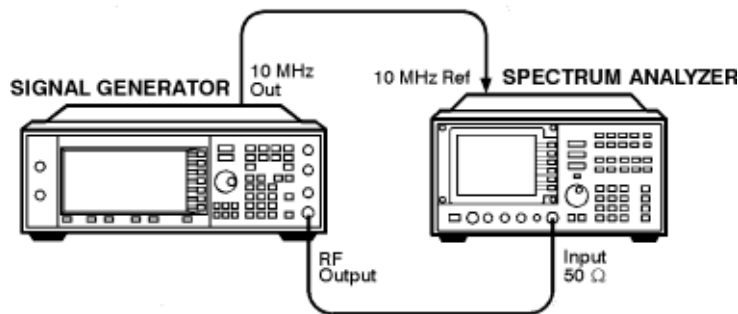

wk781a

1. Connect the equipment as shown above.
2. Preset all of the equipment.
3. Follow the instructions as they appear on the controller's display.

---

## Lock Angle Potentiometer Adjustment

### Description

This test is used to optimize the phase detector sampling of the synthesizer phase-locked loop reference frequencies. The lock angle adjustment sets the time during the reference cycle when the ultra-quiet time phase detector measurement occurs. The phase detector needs to make its measurement at the quietest point in the reference cycle. By adjusting this potentiometer to minimize the level of the fractional-N spur, the time of the phase detector sample can be optimized.

### Required Test Equipment

- HP 8563E Spectrum Analyzer

### Procedure

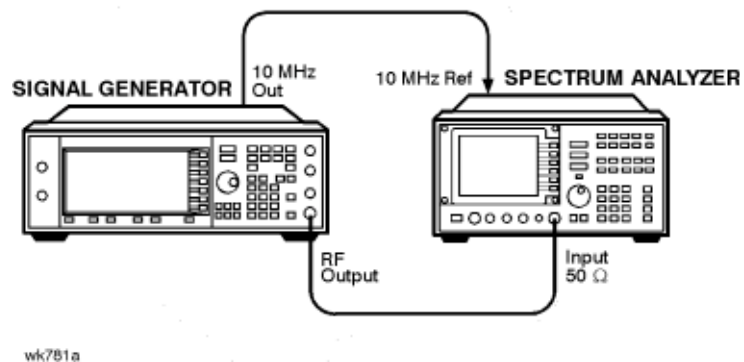

1. Connect the equipment as shown above.
2. Preset all of the equipment.
3. Follow the instructions as they appear on the controller's display.

---

## KV versus Frequency Calibration

### Description

This test determines the tuning sensitivity of the synthesizer loop. To measure the sensitivity, the tuning voltage is measured as the frequency is stepped from 500 to 1000 MHz in 10 MHz steps. At each incremental frequency the tuning voltage is measured (Vtune1) and again at the incremental frequency +300 kHz (Vtune2). The sensitivity is then calculated in units of MHz/V and stored in the instrument's firmware.

### Required Test Equipment

- HP 3458A Digital Voltmeter

### Procedure

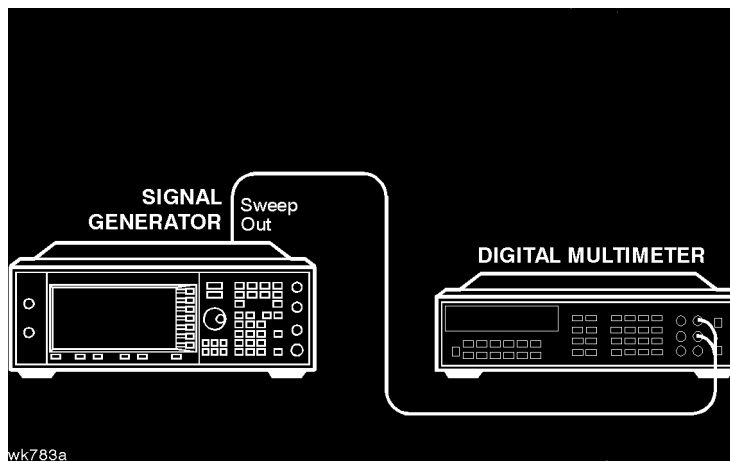

1. Connect the equipment as shown above.
2. Preset all of the equipment.
3. Follow the instructions as they appear on the controller's display.

---

## AM Audio Path Offset Calibration

### Description

This test calibrates the AM path to remove any offset generated when LIN AM, LIN BURST, or LOG BURST are enabled. This test determines the ALC\_REF\_DAC delta value which is used to correct the offset when the modulation is enabled. This value is then stored in the appropriate calibration constant.

### Required Test Equipment

- HP 438A Power Meter
- HP 8482A Power Sensor

### Procedure

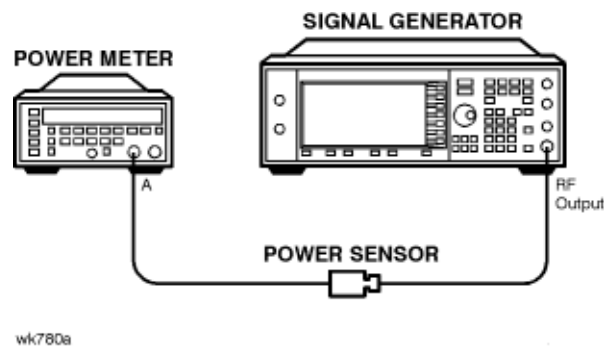

1. Connect the equipment as shown above.
2. Preset all of the equipment.
3. Follow the instructions as they appear on the controller's display.

---

## Timebase DAC Calibration

### Description

This test insures that the instrument has warmed-up sufficiently, then adjusts the coarse and fine reference timebase DACs for minimum internal reference frequency error. The coarse and fine DAC calibration factors are then stored in the instrument's firmware.

### Required Test Equipment

- HP 53132A Universal Counter
- HP 5071A Primary Frequency Standard

### Procedure

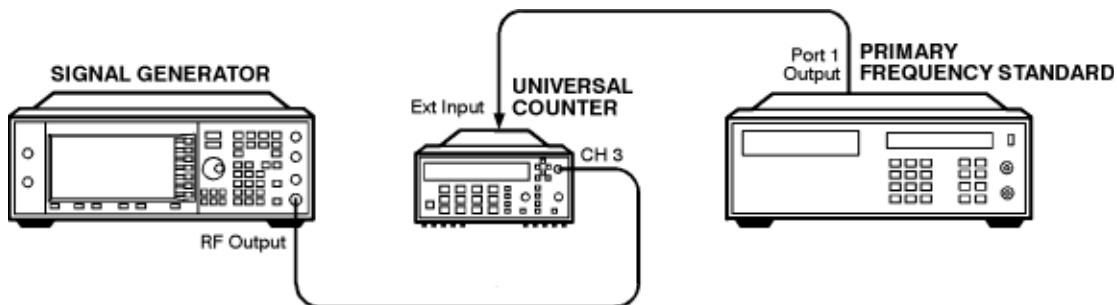

wk7101a

1. Connect the equipment as shown above.
2. Preset all of the equipment.
3. Follow the instructions as they appear on the controller's display.

---

## FM Scale DAC Offset Calibration

### Description

This test is used to remove the offset associated with the FM SCALE DAC operational amplifier located on the reference board. This calibration results in a DAC value for FM OFFSET DAC 2. After this DAC value has been properly adjusted, the effects of the FM SCALE DAC value on the offset will be minimized.

### Required Test Equipment

- HP 53132A Universal Counter

### Procedure

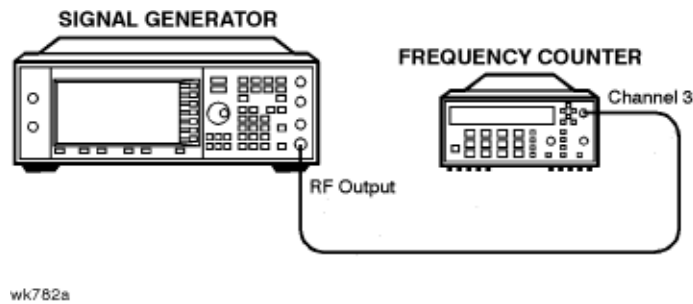

1. Connect the equipment as shown above.
2. Preset all of the equipment.
3. Follow the instructions as they appear on the controller's display.



---

## FM Path Offset Calibration

### Description

This test is used to remove the offsets associated with the various FM1 and FM2 audio paths on the reference board. When FM is enabled, voltage offsets on the reference and synthesizer boards appear as frequency shifts on the synthesizer VCO. By using a frequency counter to measure the frequency of the VCO, the voltage offsets can be quantified. The voltage offsets are adjusted and stored in the instrument's firmware.

### Required Test Equipment

- HP 53132A Universal Counter

### Procedure

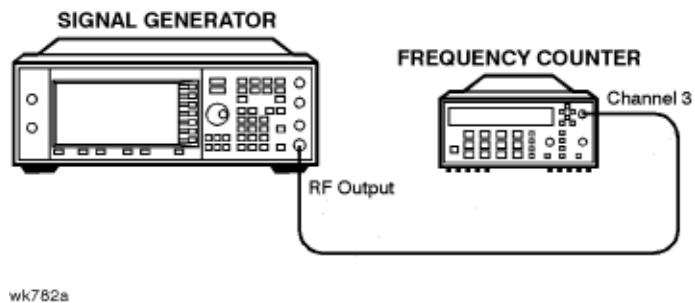

1. Connect the equipment as shown above.
2. Preset all of the equipment.
3. Follow the instructions as they appear on the controller's display.

---

## FM In-Band DAC Offset Calibration

### Description

This test is used to remove the offset associated with the FM IN-BAND DAC located on the synthesizer board. The calibration determines the DAC value for the FM IN-BAND OFFSET DAC on the synthesizer board which will remove the offset associated with the FM IN-BAND DAC.

### Required Test Equipment

- HP 53132A Universal Counter

### Procedure

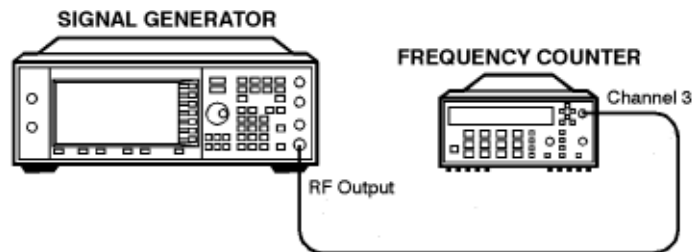

wk782a

1. Connect the equipment as shown above.
2. Preset all of the equipment.
3. Follow the instructions as they appear on the controller's display.

---

## FM Inverting Amplifier Offset Calibration

### Description

This test is used to remove the offset associated with the differential inverting amplifier on the FM input of the synthesizer board. The calibration determines the DAC value for the FM OFFSET DAC 1 on the reference board which will remove the offset associated with the amplifier.

### Required Test Equipment

- None

### Procedure

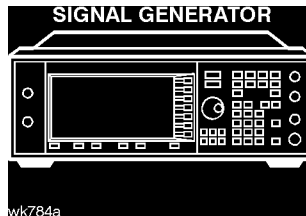

1. Connect the equipment as shown above.
2. Preset all of the equipment.
3. Follow the instructions as they appear on the controller's display.

---

## FM 1/2 Path Ratio Gain Calibration

### Description

This test equalizes the gain between the FM1 and FM2 paths. The gain of the FM2 path is adjusted using the FM SCALE DAC and the resulting DAC value is stored in the instrument's firmware. This calibration only affects source-independent gains. When uncalibrated sources feed into the paths, the gains are adjusted using the Modulation Source Relative Gain Calibration.

### Required Test Equipment

- HP 3458A Digital Voltmeter
- HP 53132A Universal Counter
- HP 33120A 15 MHz Function/Arbitrary Waveform Generator

### Procedure

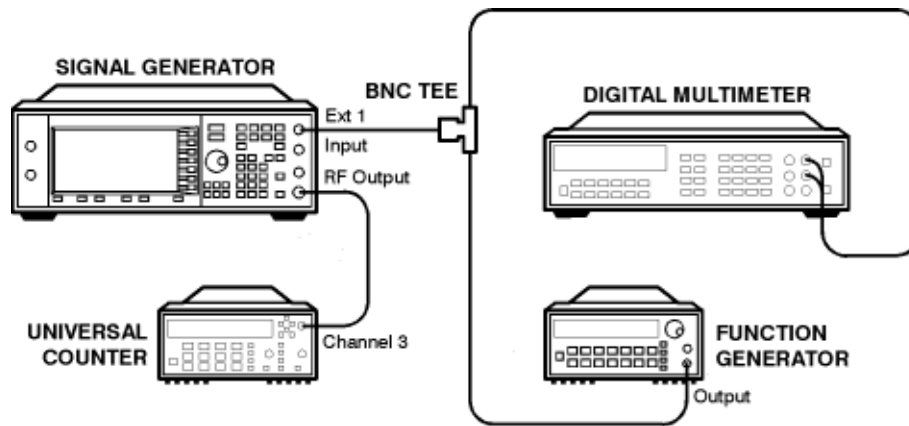

wk785a

1. Connect the equipment as shown above.
2. Preset all of the equipment.
3. Follow the instructions as they appear on the controller's display.

---

## Modulation Source Relative Gain Compression Calibration

### Description

This test provides a scaling factor for all of the multiplexed FM modulation inputs. The scaling factor is used by the instrument's firmware to scale the actual requested FM deviation from the synthesizer board when the corresponding input is selected. Three scaling factors (EXT1, EXT2, and INT1) are generated during this calibration. The resulting values are used to calculate the calibration values that are then stored in the instrument's firmware.

### Required Test Equipment

- HP 3458A Digital Voltmeter
- HP 53132A Universal Counter
- HP 33120A 15 MHz Function/Arbitrary Waveform Generator

### Procedure

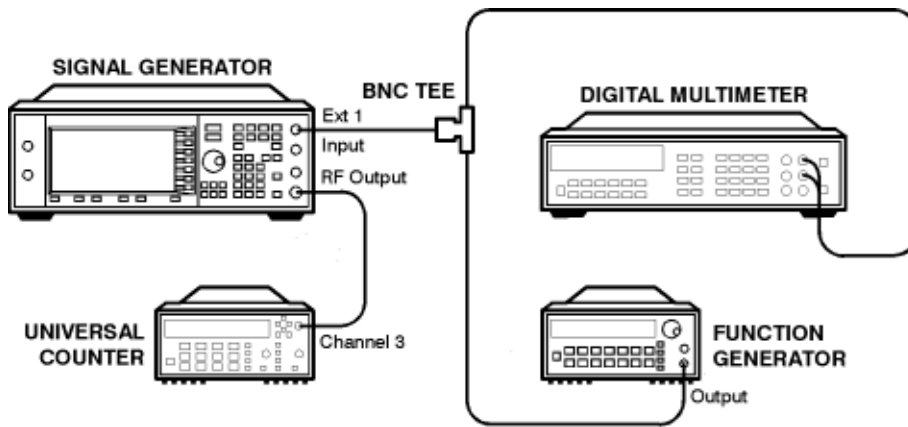

wk785a

1. Connect the equipment as shown above.
2. Preset all of the equipment.
3. Follow the instructions as they appear on the controller's display.

---

## FM Out-Of-Band Calibration

### Description

This test adjusts the FM out-of-band deviation to match the in-band FM deviation. It also determines the attenuation values of the out-of-band attenuators and sets the values of so other FM constants. The loop bandwidth of the synthesizer phase-locked loop is approximately 5 kHz. This calibration is used to set the FM deviation at rates above the loop bandwidth (out-of-band) so they will equal the deviation rates within the loop bandwidths (in-band).

### Required Test Equipment

- HP 3458A Digital Voltmeter
- HP 8902A Measuring Receiver
- HP 33120A 15 MHz Function/Arbitrary Waveform Generator

### Procedure

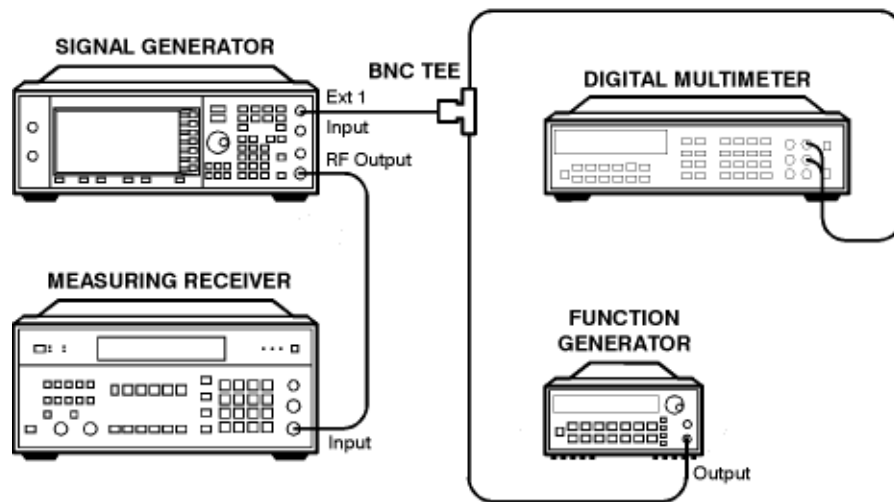

wk786a

1. Connect the equipment as shown above.
2. Preset all of the equipment.
3. Follow the instructions as they appear on the controller's display.

---

## FM Delay Potentiometer Adjustment

### Description

This test adjusts the match between the delay of the signal passing through the FM in-band path to the delay of the signal passing through the FM out-of-band path. This calibration is the final adjustment required to achieve good FM performance over a wide range of different rates. The FM delay potentiometer forms part of an RC network on the input of the FM out-of-band circuit. The adjustment is used to flatten the delay of the FM response from low rates to high rates. The delay affects the deviation accuracy. By monitoring the deviation, the delay can be adjusted.

### Required Test Equipment

- HP 3458A Digital Voltmeter
- HP 8902A Measuring Receiver
- HP 33120A 15 MHz Function/Arbitrary Waveform Generator

### Procedure

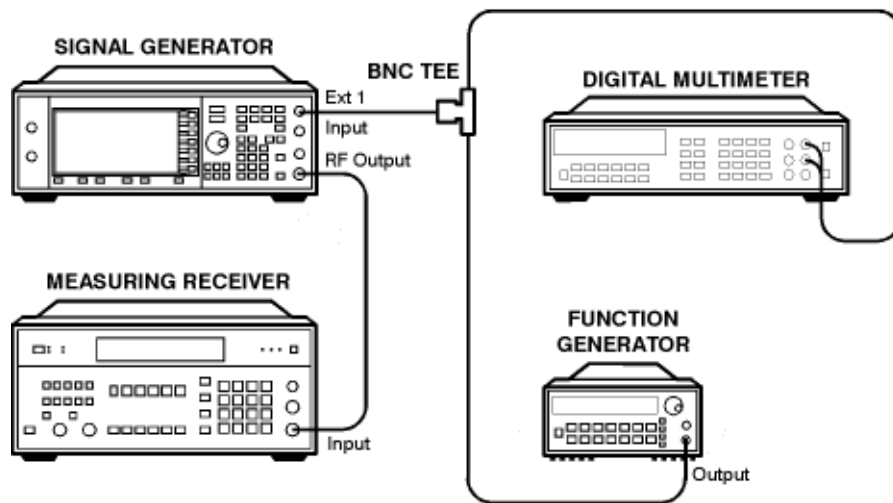

wk786a

1. Connect the equipment as shown above.
2. Preset all of the equipment.
3. Follow the instructions as they appear on the controller's display.

---

## Wide Bandwidth Phase Modulation Calibration

### Description

This test is used to calibrate the phase modulation circuitry on the synthesizer board. The phase modulation has two operational modes: normal and wide bandwidth. This calibration determines the attenuation correction factors for maximum deviation for each of the phase modulation out-of-band ranges for normal and wide bandwidth modes and in-band and out-of-band operation. This calibration **MUST** be performed at the same frequency as the FM out-of-band calibration (1 GHz). The resulting correction factors are then stored in the instrument's firmware.

### Required Test Equipment

- HP 3458A Digital Voltmeter
- HP 8902A Measuring Receiver
- HP 33120A 15 MHz Function/Arbitrary Waveform Generator

### Procedure

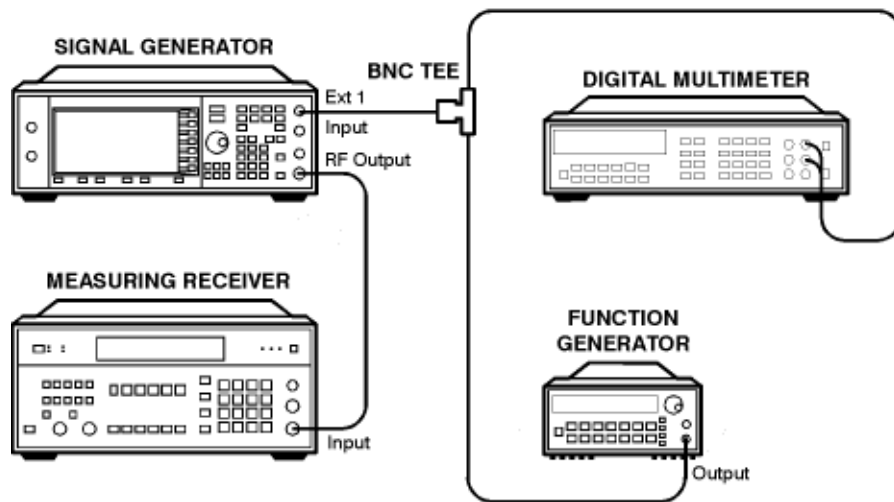

wk786a

1. Connect the equipment as shown above.
2. Preset all of the equipment.
3. Follow the instructions as they appear on the controller's display.



---

## DCFM Calibration

### Description

This test removes all of the DC offsets associated with the FM path while in DCFM mode. This test uses only the FM1 path to verify the functionality of the circuitry. The resulting values are stored in the instrument's firmware.

### Required Test Equipment

- HP 53132A Universal Counter

### Procedure

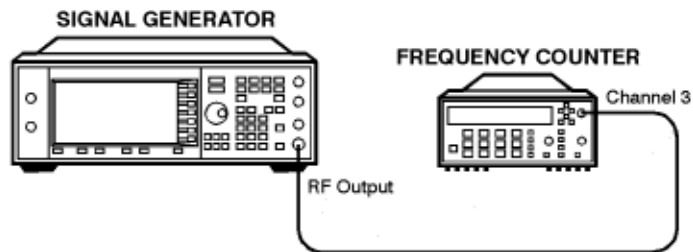

wk7B2a

1. Connect the equipment as shown above.
2. Preset all of the equipment.
3. Follow the instructions as they appear on the controller's display.

---

## Low Frequency (LF) Output Calibration

### Description

The LF output provides a calibrated audio frequency signal. This test is used to set the full-scale amplitude of the LF-OUT DAC on the reference board. When the calibration is complete, the voltage on the LF output should be equal to the input voltage plus or minus 1mV. The resulting DAC values are then stored in the instruments firmware.

### Required Test Equipment

- HP 3458A Digital Voltmeter

### Procedure

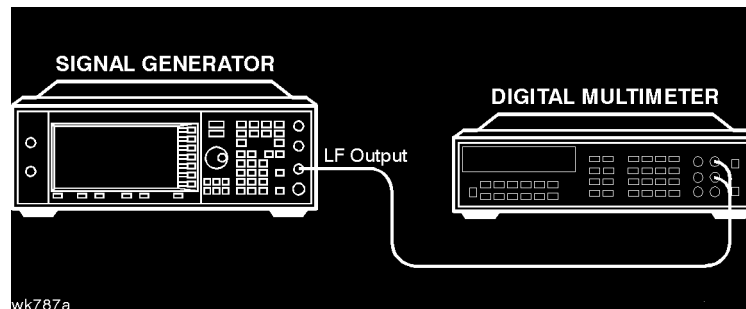

1. Connect the equipment as shown above.
2. Preset all of the equipment.
3. Follow the instructions as they appear on the controller's display.

---

## External Input Peak Detector Calibration

### Description

This test is used to calibrate the positive trip level of the EXT1 and EXT2 peak detectors located on the reference board. The calibration generates DAC values for the modulation comparator DACs which provide an voltage to the window comparator operational amplifiers. When the peak detector level DACs are set correctly, the overmodulation indicator will trigger whenever the voltage to the EXT1/EXT2 input is greater than 1.03V. The resulting DAC values are saved as a calibration constant in the instrument's firmware.

### Required Test Equipment

- HP 3458A Digital Voltmeter
- HP 33120A 15 MHz Function/Arbitrary Waveform Generator

### Procedure

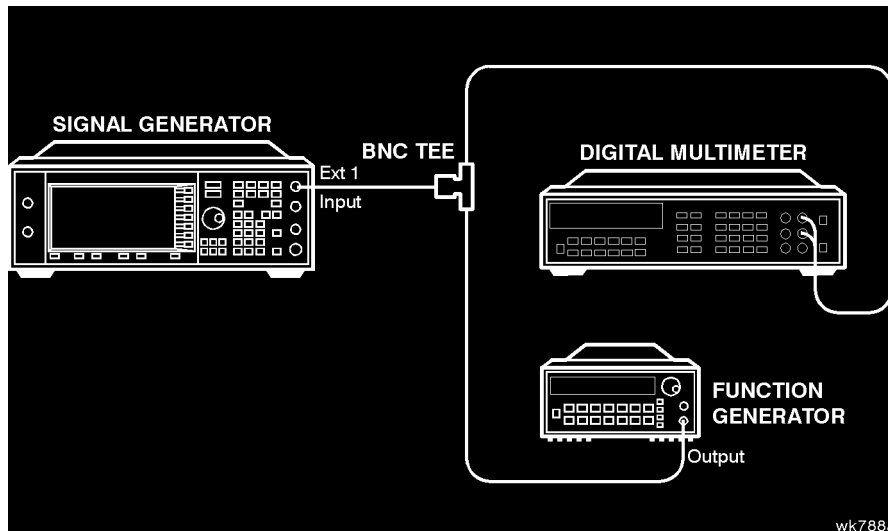

1. Connect the equipment as shown above.
2. Preset all of the equipment.
3. Follow the instructions as they appear on the controller's display.

---

## Burst Modulator Calibration

### Description

This test is used to adjust the bias modulator circuitry to provide an accurate logarithmic drop in power level for a linear input voltage. When properly adjusted, a one-volt signal on the input will result in a 10 dB drop in power level. The adjustment involves the adjustment of three DACs (BURST BIAS, BURST GAIN, and BURST OFFSET) at several different frequencies. The BURST OFFSET DAC sets the initial current level through the burst modulator diode. The BURST GAIN DAC is used to calibrate the input voltage level to the burst driver circuit. The BURST BIAS DAC sets the breakpoint at which the modulator switches from a logarithmic to a linear transfer function. The results are stored in the calibration arrays associated with each DAC.

### Required Test Equipment

- HP 8904A Audio Source
- HP 8563E Spectrum Analyzer
- HP E4400-60073 Digital Test Card

## Procedure

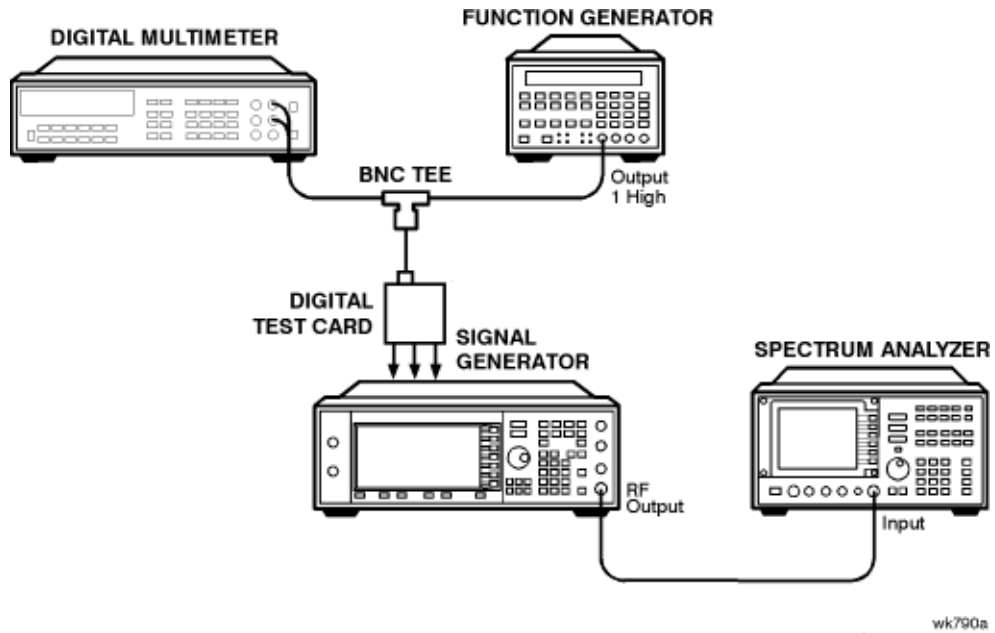

1. Connect the equipment as shown above.
2. Preset all of the equipment.
3. Follow the instructions as they appear on the controller's display.

---

## Burst Audio Path Gain Calibration

### Description

This test adjusts the scaling of the linear burst audio path until a -0.99 Vdc input to the EXT1 connector results in a 40 dB drop in power relative to 0.00 Vdc input when linear burst is activated. The AM 1 DAC value is changed until this result is achieved and its value is stored as a calibration array.

### Required Test Equipment

- HP 3458A Digital Voltmeter
- HP 33120A 15 MHz Function/Arbitrary Waveform Generator
- HP 8563E Spectrum Analyzer

### Procedure

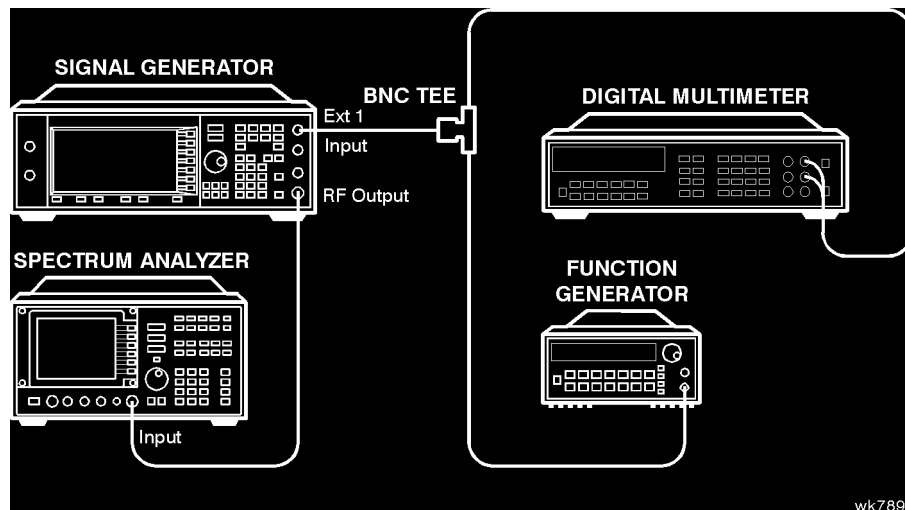

1. Connect the equipment as shown above.
2. Preset all of the equipment.
3. Follow the instructions as they appear on the controller's display.

---

## Prelevel Calibration

### Description

This test calibrates the PRE LEVEL REF DAC on the output board. This DAC is used to control the RF power level that is incident upon the marble I/Q modulator by setting the control point for the prelevel loop. The prelevel loop detector is on the output of the marble I/Q modulator, its drive circuitry on the output board, and its RF modulator on the synthesizer board. This calibration ensures that there will be sufficient power available at the marble I/Q modulator to perform the desired modulation while minimizing intermodulation distortion when the digital modulation is activated. The instrument is set to a frequency and the auxiliary output amplitude level is adjusted using the PRE LEVEL DAC to within the specified tolerance of the desired value. This process is repeated for all the frequencies in the marble I/Q modulator index array. The results are then stored in the instrument's firmware.

### Required Test Equipment

- HP 438A Power Meter
- HP 8482A Power Sensor

### Procedure

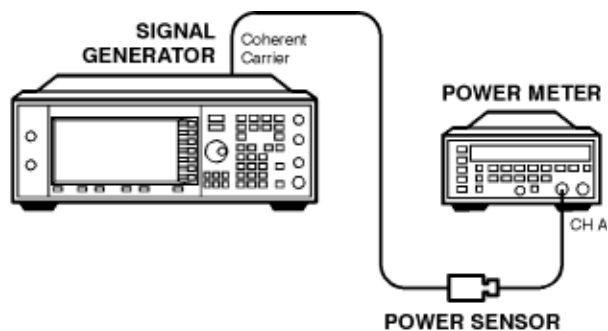

wk7100a

1. Connect the equipment as shown above.
2. Preset all of the equipment.
3. Follow the instructions as they appear on the controller's display.

---

## Gain Adjust Calibration

### Description

This test calibrates GAIN ADJUST DAC on the output board. This DAC is used to control the RF power level that is incident upon the switched filters and subsequent RF amplifiers by setting the control point for the gain adjust modulator. This calibration ensures that there will be sufficient power available at the RF amplifiers to perform the desired modulation while minimizing intermodulation distortion when the digital modulation is activated. After adjustment, the results are stored in the instrument's firmware.

### Required Test Equipment

- HP 438A Power Meter
- HP 8482A Power Sensor

### Procedure

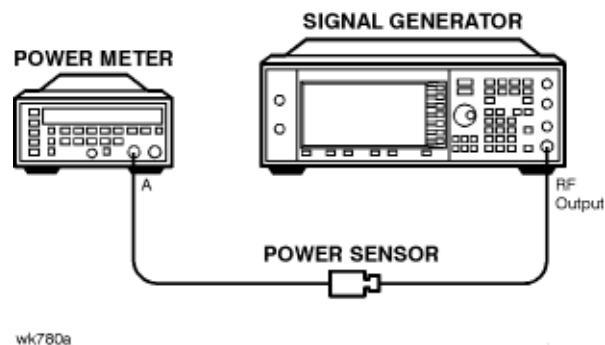

1. Connect the equipment as shown above.
2. Preset all of the equipment.
3. Follow the instructions as they appear on the controller's display.



---

## ALC Modulation Driver Bias Calibration

### Description

This test adjusts the ALC MOD DRV BIAS DAC on the output board. This DAC is used to control the bias current to the ALC modulator driver. It is primarily used to accommodate unmatched VBE values in the drives, but has a strong influence on modulator gain. This test adjusts the DAC until the ALC modulator gain is balanced around its nominal design center. The results are stored as a calibration array in the instrument's firmware.

### Required Test Equipment

- None

### Procedure

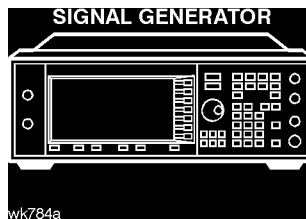

1. Connect the equipment as shown above.
2. Preset all of the equipment.
3. Follow the instructions as they appear on the controller's display.

---

## VBLO Mixer Bias Calibration

### Description

This test calibrates VBLO MIXER BIAS DAC on the output board. This DAC is used to control the bias voltage to the internal marble mixers. This DAC is primarily used to adjust the mixer bias for optimum I/Q modulation linearity, but it has a secondary influence on mixer gain. This calibration ensures that there will be sufficient power available through the marble mixers to perform the desired modulation while minimizing intermodulation distortion when the digital modulation is activated. After adjustment, the results are stored in the instrument's firmware.

### Required Test Equipment

- None

### Procedure

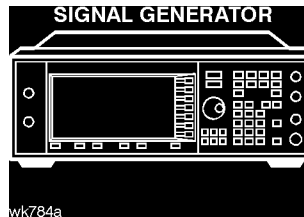

1. Connect the equipment as shown above.
2. Preset all of the equipment.
3. Follow the instructions as they appear on the controller's display.

---

## Automatic Leveling Control (ALC) Calibration

### Description

This test is used to achieve a four-point fit of power level accuracy over the ALC REF DAC settings of 1300, 1800, 2300, and 2700. Three calibration constants and the BULK R ADJ potentiometer are used to calibrate the ALC. Closed loop and open loop calibrations are adjusted separately. The resulting values are stored as calibration arrays in the instrument's firmware.

### Required Test Equipment

- HP 438A Power Meter
- HP 8482A Power Sensor

### Procedure

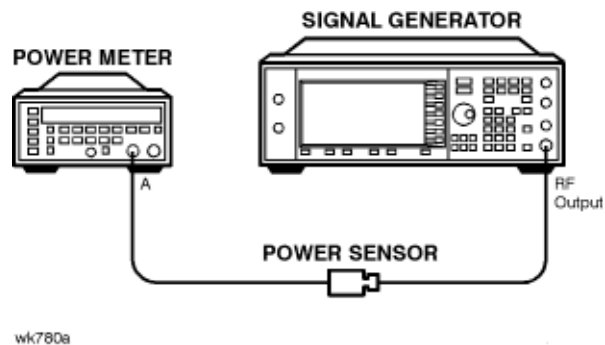

1. Connect the equipment as shown above.
2. Preset all of the equipment.
3. Follow the instructions as they appear on the controller's display.

---

## Power Flatness Calibration

### Description

This test adjusts the output power to be flat across the instrument's entire operating range. The ALC REF DAC is set to 2048, which nominally sets the power to 0 dBm at the RF output. The exact power level is then measured and a correction factor is generated which is then used to offset the ALC REF DAC until an output power level of 0 dBm is achieved. The results are stored as a calibration array in the instrument's firmware.

### Required Test Equipment

- HP 438A Power Meter
- HP 8482A Power Sensor

### Procedure

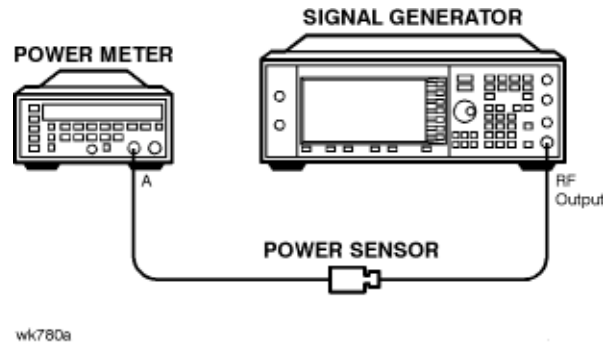

1. Connect the equipment as shown above.
2. Preset all of the equipment.
3. Follow the instructions as they appear on the controller's display.

---

## Attenuator Calibration (Power Meter)

### Description

This test is used to calibrate the output power when the attenuator is set at -5, -10, and -15 dB. To calibrate each attenuator step, the attenuator is set to the correct internal attenuation using an internal attenuator latch command. Two power measurements are triggered: one without the attenuator and one with the attenuator. The difference between the expected attenuation and the measured attenuation is stored in the appropriate calibration array.

### Required Test Equipment

- HP 438A Power Meter
- HP 8482A Power Sensor

### Procedure

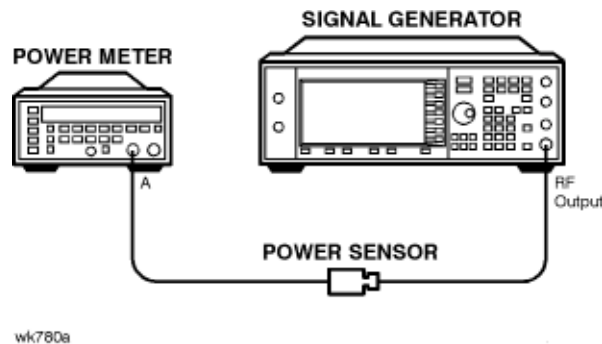

1. Connect the equipment as shown above.
2. Preset all of the equipment.
3. Follow the instructions as they appear on the controller's display.

---

## Level Meter Calibration

### Description

This test determines the level meter gain and offset calibration constants on the output board. The level meter function is used when the ALC loop is open. It allows the output power of the instrument to be monitored and controlled without using the ALC loop. After the level meter gain and offsets are measured, a calibration constant is calculated and stored in the appropriate calibration array.

### Required Test Equipment

- None

### Procedure

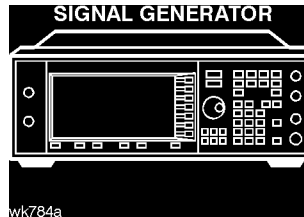

1. Connect the equipment as shown above.
2. Preset all of the equipment.
3. Follow the instructions as they appear on the controller's display.

---

## ALC Modulation Flatness Calibration

### Description

This test calibrates the ALC REF DAC corrections necessary to maintain power flatness in the ALC open-loop mode of operation. The nominal ALC REF DAC settings are adjusted to re-align the ALC open-loop power with the desired level. The resulting values are stored as calibration arrays in the instrument's firmware.

### Required Test Equipment

- HP 438A Power Meter
- HP 8482A Power Sensor

### Procedure

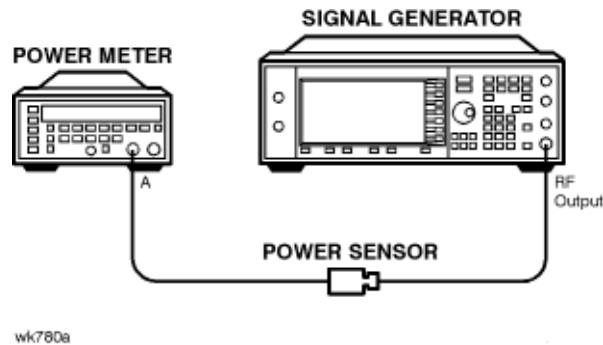

1. Connect the equipment as shown above.
2. Preset all of the equipment.
3. Follow the instructions as they appear on the controller's display.

---

## AM Gain Calibration

### Description

This test adjusts the gain of the AM circuitry to provide a 10 dB drop for a one-volt input signal. First a power level is set and a one-volt signal is connected to the input. AM is enabled and the AM DACs are adjusted for an exact 10 dB drop. The resulting DAC value is stored as a calibration array.

### Required Test Equipment

- HP 438A Power Meter
- HP 8482A Power Sensor
- HP 33120A 15 MHz Function/Arbitrary Waveform Generator

### Procedure

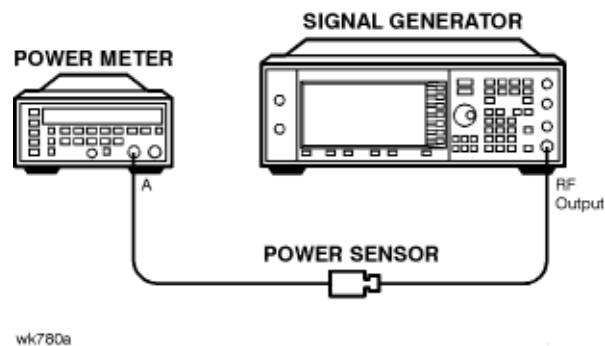

1. Connect the equipment as shown above.
2. Preset all of the equipment.
3. Follow the instructions as they appear on the controller's display.



---

## Low Level Step Attenuator Calibration

### Description

**NOTE:** The accuracy of this test depends on the accuracy of the Attenuator Calibration (Power Meter). You must perform the Attenuator Calibration (Power Meter) before you perform the following adjustment.

Measurement accuracy at low power levels is dependant on a good signal-to-noise ratio (SNR). This adjustment first insures that the measurement system's noise floor is not above a specific level. During this verification, spectrum analyzer residuals are also checked. If a residual is found, the adjustment for that frequency is shifted 25 Hz to avoid the residual.

This calibration procedure is based on relative power measurements using a spectrum analyzer. The reference for all measurements is the -10 dBm level adjusted in the Attenuator Calibration (Power Meter) procedure. For signal levels below -70 dBm, low noise amplifiers are inserted to maximize the signal-to-noise ratio at low levels. Note that all subsequent measurements are relative to -70 dBm (the lowest signal level measured without the amplifiers). Note also that all attenuator calibration arrays for 20 dB and below are filled with zero after the noise floor measurement. If an adjustment is interrupted after the arrays are zeroed, low level power accuracy will be affected.

### Required Test Equipment

- HP 8563E Spectrum Analyzer
- HP 8447D Option 011 .1 to 1300 MHz Dual Preamplifier
- HP 8449D 1 to 26.5 GHz Preamplifier
- HP 8491A/B Option 006 Attenuator (6 dB)

Procedure

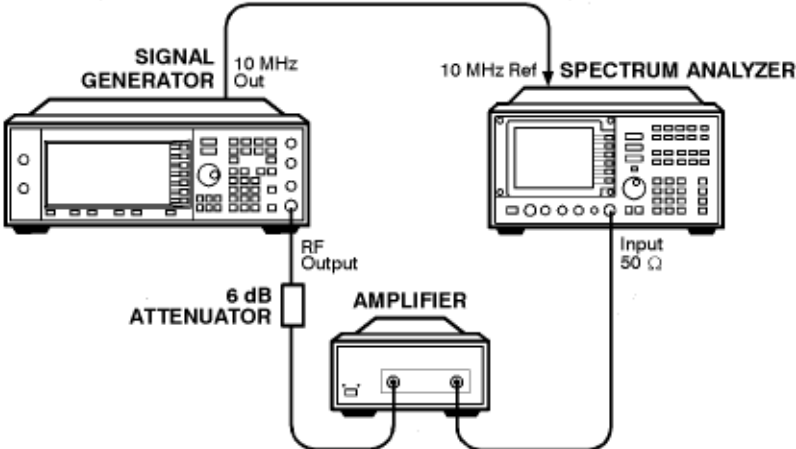

wk7103a

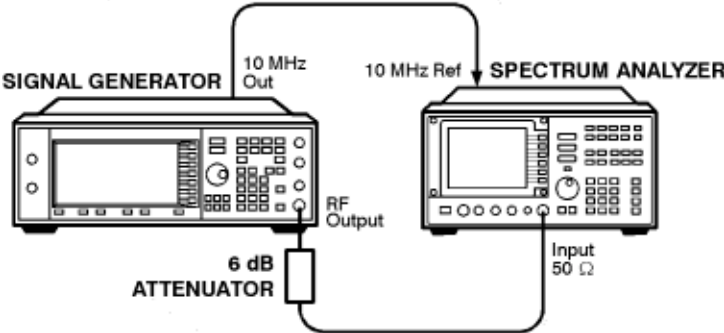

wk7104a

## Adjustments

### Low Level Step Attenuator Calibration

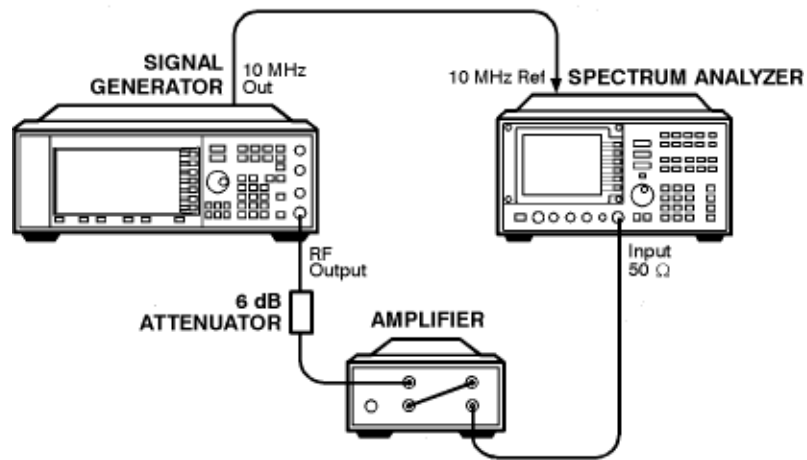

wk7102a

1. Connect the equipment as shown in the first illustration above.
2. Preset all of the equipment.
3. Follow the instructions as they appear on the controller's display.

---

## **7 Maintenance and Service**

---

This chapter contains preventive maintenance procedures, and it explains how to return your signal generator to HP for service.

## **Preventive Maintenance Procedures**

The HP ESG Series Signal Generators require no regular maintenance. This section contains cleaning procedures for the signal generator.

### **Cleaning the Cabinet**

Use a damp cloth to clean the exterior the instrument. Do not use any cleaning products.

### **Cleaning the Display**

Use a soft cloth to clean the window in front of the display assembly. Isopropyl alcohol can also be used on the window for dirt that is difficult to remove. Do not use these products on the display assembly. Refer to the service guide, if the display assembly requires cleaning.

---

## Returning Your Signal Generator to HP

If you are returning your signal generator to HP for servicing, fill out and attach a blue repair tag to the instrument. Repair tags are located at the end of this chapter.

Include as much information as possible about the problem: record any error messages that appeared on the display, and include performance test results or any other specific data on the performance of the signal generator.

Ship the instrument in the original factory packaging materials, if they are available. If not, use similar packaging to properly protect the instrument.

Return the instrument to the nearest HP sales and service office. A list of sales and service offices follows on the next page.

## HP Sales and Service Offices

US FIELD OPERATIONS			
<b>Headquarters</b> Hewlett-Packard Company 19320 Pruneridge Avenue Cupertino, CA 95014, USA (800) 752-0900	<b>California, Northern</b> Hewlett-Packard Co. 301 E. Evelyn Mountain View, CA 94041 (415) 694-2000	<b>California, Southern</b> Hewlett-Packard Co. 1421 South Manhattan Ave. Fullerton, CA 92631 (714) 999-6700	<b>Colorado</b> Hewlett-Packard Co. 24 Inverness Place, East Englewood, CO 80112 (303) 649-5512
<b>Atlanta Annex</b> Hewlett-Packard Co. 2124 Barrett Park Drive Kennesaw, GA 30144 (404) 648-0000	<b>Illinois</b> Hewlett-Packard Co. 5201 Tollview Drive Rolling Meadows, IL 60008 (847) 342-2000	<b>New Jersey</b> Hewlett-Packard Co. 150 Green Pond Road Rockaway, NJ 07866 (201) 586-5400	<b>Texas</b> Hewlett-Packard Co. 930 E. Campbell Rd. Richardson, TX 75081 (214) 231-6101
EUROPEAN FIELD OPERATIONS			
<b>Headquarters</b> Hewlett-Packard S.A. 150, Route du Nant-d'Avril 1217 Meyrin 2/Geneva Switzerland (41 22) 780.8111	<b>France</b> Hewlett-Packard France 1 Avenue Du Canada Zone D'Activite De Courtaboeuf F-91947 Les Ulis Cedex France (33 1) 69 82 60 60	<b>Germany</b> Hewlett-Packard GmbH Hewlett-Packard Strasse 61352 Bad Homburg v.d.H Germany (49 6172) 16-0	<b>Great Britain</b> Hewlett-Packard Ltd. Eskdale Road, Winnersh Triangle Wokingham, Berkshire RG41 5DZ England (44 734) 696622
INTERCON FIELD OPERATIONS			
<b>Headquarters</b> Hewlett-Packard Company 3495 Deer Creek Rd. Palo Alto, CA 94304-1316 (415) 857-5027	<b>Australia</b> Hewlett-Packard Australia Ltd. 31-41 Joseph Street Blackburn, Victoria 3130 (61 3) 895-2895	<b>Canada</b> Hewlett-Packard (Canada) Ltd. 17500 South Service Road Trans-Canada Highway Kirkland, Quebec H9J 2X8 Canada (514) 697-4232	<b>China</b> China Hewlett-Packard Co. 38 Bei San Huan XI Road Shuang Yu Shu Hai Dian District Beijing, China (86 1) 256-6888
<b>Japan</b> Hewlett-Packard Japan, Ltd. 9-1 Takakura-Cho, Hachioji Tokyo 192, Japan (81 426) 60-2111	<b>Singapore</b> Hewlett-Packard Singapore (Pte.) Ltd. 150 Beach Road #29-00 Gateway West Singapore 0718 (65) 291-9088	<b>Taiwan</b> Hewlett-Packard Taiwan 8th Floor, H-P Building 337 Fu Hsing North Road Taipei, Taiwan (886 2) 712-0404	

---

## **8 Safety and Regulatory**

---

This chapter provides product warranty information, regulatory declarations, information about ESD and restricted materials, and explanations of caution and warning statements marked on the instrument.



---

## Safety Notes

The following safety notes are used throughout this manual. Familiarize yourself with each of the notes and its meaning before operating this instrument.

---

### ***CAUTION***

Caution denotes a hazard. It calls attention to a procedure that, if not correctly performed or adhered to, would result in damage to or destruction of the product. Do not proceed beyond a caution sign until the indicated conditions are fully understood and met.

---

### ***WARNING***

**Warning denotes a hazard. It calls attention to a procedure which, if not correctly performed or adhered to, could result in injury or loss of life. Do not proceed beyond a warning note until the indicated conditions are fully understood and met.**

---

## Instrument Markings

The following markings and caution and warning labels are used on the instrument. Be sure to observe all cautions and warnings.

---

### **WARNING**

**No user serviceable parts inside. Refer servicing to qualified personnel.**



The instruction manual symbol. The product is marked with this symbol when it is necessary for the user to refer to the instructions in the manual.



The CE mark is a registered trademark of the European Community (if accompanied by a year, it is the year when the design was proven).



The CSA mark is the Canadian Standards Association safety mark.



This symbol is used to mark the on position of the power line switch.



This symbol is used to mark the standby position of the power line switch.



This symbol indicates that the input power required is AC.

ISM 1-A

This is a symbol of an Industrial Scientific and Medical Group 1 Class A product. (CISPER 11, Clause 4)

---

## General Safety Considerations

---

### ***WARNING***

**No operator serviceable parts inside. Refer servicing to qualified personnel. To prevent electrical shock do not remove covers.**

---

---

### ***WARNING***

**This is a Safety Class 1 Product (provided with a protective earthing ground incorporated in the power cord). The mains plug shall only be inserted in a socket outlet provided with a protective earth contact. Any interruption of the protective conductor inside or outside of the product is likely to make the product dangerous. Intentional interruption is prohibited.**

---

---

## Statement of Compliance

This product has been designed and tested in accordance with IEC Publication 1010, Safety Requirements for Electronic Measuring Apparatus, and has been supplied in a safe condition. The instruction documentation contains information and warnings which must be followed by the user to ensure safe operation and to maintain the product in a safe condition.

---

## Electrostatic Discharge

Electrostatic discharge (ESD) can damage or destroy electronic components. Therefore, all work performed on assemblies consisting of electronic components should be done at a static-free work station. Figure 8-1 shows an example of a static-safe work station using two kinds of ESD protection:

- conductive table mat and wrist-strap combination
- conductive floor mat and heel-strap combination

These methods may be used together or separately.

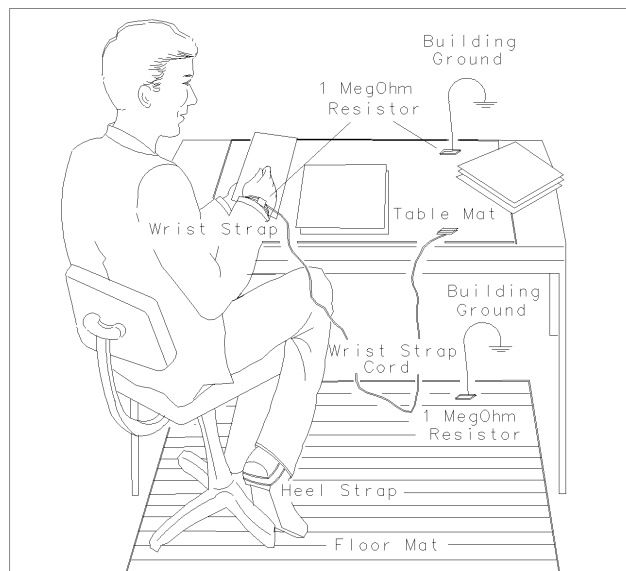

FORMAT46

**Figure 8-1. Static-Safe Work Station**

## Reducing Potential for ESD Damage

The following suggestions may help reduce ESD damage that occurs during instrument testing and servicing:

- Before connecting any coaxial cable to a connector for the first time each day, momentarily ground the center and outer connectors of the cable.
- Ground personnel with a resistor-isolated wrist strap before touching any connector and before removing any assembly from the instrument.
- All instruments should be earth-grounded to prevent build-up of static discharge.

---

## Warranty

This Hewlett-Packard instrument product is warranted against defects in material and workmanship for a period of one year from date of shipment. During the warranty period, Hewlett-Packard Company will, at its option, either repair or replace products which prove to be defective.

For warranty service or repair, this product must be returned to a service facility designated by Hewlett-Packard. Buyer shall prepay shipping charges to Hewlett-Packard and Hewlett-Packard shall pay shipping charges to return the product to Buyer. However, Buyer shall pay all shipping charges, duties, and taxes for products returned to Hewlett-Packard from another country.

Hewlett-Packard warrants that its software and firmware designated by Hewlett-Packard for use with an instrument will execute its programming instructions when properly installed on that instrument. Hewlett-Packard does not warrant that the operation of the instrument, or software, or firmware will be uninterrupted or error-free.

### LIMITATION OF WARRANTY

The foregoing warranty shall not apply to defects resulting from improper or inadequate maintenance by Buyer, Buyer-supplied software or interfacing, unauthorized modification or misuse, operation outside of the environmental specifications for the product, or improper site preparation or maintenance.

NO OTHER WARRANTY IS EXPRESSED OR IMPLIED. HEWLETT-PACKARD SPECIFICALLY DISCLAIMS THE IMPLIED WARRANTIES OF MERCHANTABILITY AND FITNESS FOR A PARTICULAR PURPOSE.

### EXCLUSIVE REMEDIES

THE REMEDIES PROVIDED HEREIN ARE BUYER'S SOLE AND EXCLUSIVE REMEDIES. HEWLETT-PACKARD SHALL NOT BE LIABLE FOR ANY DIRECT, INDIRECT, SPECIAL, INCIDENTAL, OR CONSEQUENTIAL DAMAGES, WHETHER BASED ON CONTRACT, TORT, OR ANY OTHER LEGAL THEORY.

---

## **Assistance**

Product maintenance agreements and other customer assistance agreements are available for Hewlett-Packard products. For any assistance, contact your nearest Hewlett-Packard sales and service office. Refer to the list of sales and service offices in Chapter 3.

---

## **Certification**

Hewlett-Packard Company certifies that this product met its published specifications at the time of shipment from the factory. Hewlett-Packard further certifies that its calibration measurements are traceable to the United States National Institute of Standards and Technology, to the extent allowed by the Institute's calibration facility, and to the calibration facilities of other International Standards Organization members.





---

## Index

### A

AC symbol, 8-3  
accessories, 1-16  
accuracy  
  AM, 5-12  
  FM, 5-11  
  phase modulation, 5-16  
adjustments, 6-1  
  ALC modulation driver bias, 6-30  
  ALC modulation flatness, 6-36  
  AM audio path offset, 6-11  
  AM gain, 6-37  
  analog bus ADC, 6-6  
  attenuator (power meter), 6-34  
  automatic leveling control, 6-32  
  burst audio path gain, 6-27  
  burst modulator, 6-25  
  DCFM, 6-22  
  external input peak detector, 6-24  
  FM 1/2 path ratio gain, 6-17  
  FM delay potentiometer, 6-20  
  FM in-band DAC offset, 6-15  
  FM inverting amplifier offset, 6-16  
  FM out-of-band, 6-19  
  FM path offset, 6-14  
  FM scale DAC offset, 6-13  
  gain adjust, 6-29  
  internal reference oscillator, 6-4  
  internal source, 6-7  
  KV versus frequency, 6-10  
  level meter, 6-35  
  lock angle potentiometer, 6-9  
  low frequency output, 6-23  
  low level step attenuator, 6-38  
  modulation source relative gain  
    compression, 6-18  
  power flatness, 6-33  
  prelevel, 6-28  
  relationships between adjustments,  
    6-2  
  timebase DAC, 6-12  
  VBLO mixer bias, 6-31  
  VCO bias potentiometer, 6-8  
  wide bandwidth phase modulation,  
    6-21  
AM  
  accuracy, 5-12  
  distortion, 5-12  
  frequency response performance test,  
    5-18  
AM accuracy check, 3-17  
amplitude modulation

  specifications, 1-11  
analyzer  
  audio, 2-2  
  spectrum, 2-2  
arbitrary waveform generator, 2-3  
assistance, 8-8  
attenuator, 2-4  
audio analyzer, 2-2

### C

calibration cycle, 5-2  
Canadian Standards Association, 8-3  
carrier frequency offset, 5-21  
caution sign, 8-2  
CE mark, 8-3  
certification  
  specifications, 8-9  
  traceability, 8-9  
compliance  
  statement of, 8-5  
computer, 2-4  
counter  
  frequency, 2-3  
  universal, 2-3  
CSA mark, 8-3

### D

DCFM frequency offset relative to CW  
  performance test, 5-21  
digital multimeter, 2-4  
digital oscilloscope, 2-2  
distortion  
  AM, 5-12  
  FM, 5-11  
  phase modulation, 5-16  
DUT selection window, 5-6

### E

equipment  
  software, 4-2  
European Community trademark, 8-3  
exiting support software, 5-10

### F

FM  
  accuracy, 5-11  
  distortion, 5-11  
  frequency response performance test,  
    5-17  
FM accuracy check, 3-15  
frequency

  counter, 2-3  
  standard, 2-2  
frequency modulation specifications,  
  1-8  
frequency offset, 5-21  
frequency range and accuracy check,  
  3-4  
frequency specifications, 1-2  
function generator, 2-3

### G

general specifications, 1-16  
generator  
  arbitrary waveform, 2-3  
  function, 2-3  
  signal, 2-2

### H

harmonic spurious signals, 5-25  
harmonic, subharmonic, and  
  nonharmonic spurious signals  
  performance test, 5-25  
HP-IB  
  interface card, 2-4

### I

IEC Publication 1010, 8-5  
installation, software, 4-3  
instruction manual symbol, 8-3  
instrument markings, 8-3  
interface card  
  HP-IB, 2-4  
internal  
  AM accuracy and distortion  
    performance test, 5-12  
  FM accuracy and distortion  
    performance test, 5-11  
  timebase, 5-30  
internal modulation input  
  specifications, 1-14  
internal modulation specifications, 1-13  
internal reference oscillator  
  specifications, 1-4  
ISM 1-A symbol, 8-3  
ISO compliance, 1-15

### L

LF out specifications, 1-14  
list  
  performance test, 5-7  
  test equipment, 5-7

---

## Index

### M

main test and results window, 5-9  
maintenance agreements, 8-8  
measuring receiver, 2-2  
meter  
    power, 2-3  
mixer, 2-3  
modulation  
    capability, 5-34  
    source frequency accuracy  
    performance test, 5-3, 5-34

### N

NIST, 8-9  
nonharmonic spurious signals, 5-25

### O

Operation, 3-1  
operation verification, 3-1  
options, 1-17  
oscilloscope, 2-2  
output  
    specifications, 1-4  
output power level check, 3-6

### P

PC, 2-4  
performance test  
    list, 5-7  
    modulation source frequency  
        accuracy, 5-3, 5-34  
    records, 5-3, 5-35, 5-36, 5-37  
    records, photocopying, 5-35  
    timebase aging rate, 5-3  
performance tests  
    AM frequency response, 5-18  
    DCFM frequency offset relative to  
        CW, 5-21  
    FM frequency response, 5-17  
    harmonic, subharmonic, and  
        nonharmonic spurious signals,  
        5-25  
    internal AM accuracy and distortion,  
        5-12  
    internal FM accuracy and distortion,  
        5-11  
    phase modulation accuracy and  
        distortion, 5-16  
    phase modulation frequency response,  
        5-20  
    power level accuracy, 5-26

    pulse modulation on/off ratio, 5-33  
    residual FM, 5-22  
personal computer, 2-4  
phase modulation  
    accuracy, 5-16  
    distortion, 5-16  
phase modulation accuracy and  
    distortion performance test, 5-16  
phase modulation frequency response  
    performance test, 5-20  
phase modulation specifications, 1-10  
photocopying performance test records,  
    5-35  
power  
    meter, 2-3  
    sensor, 2-3  
power level accuracy performance test,  
    5-26  
power on symbol, 8-3  
preamplifier, 2-3  
printer, 2-4  
printing test results, 5-10  
pulse modulation on/off ratio  
    performance test, 5-33  
pulse modulation specifications, 1-12

### R

receiver  
    measuring, 2-2  
recommended test equipment, 5-4  
records  
    performance test, 5-3, 5-35, 5-36,  
        5-37  
remote programming specifications,  
    1-15  
residual FM performance test, 5-22  
running the performance tests, 5-5

### S

safety, 8-1  
save as window, 5-8  
saving test results, 5-8  
select test equipment and tests window,  
    5-7  
sensor  
    power, 2-3  
service software, 4-1  
signal generator, 2-2  
simultaneous modulation  
    specifications, 1-15  
software

    adding datapacks, 4-17  
    adding device drivers, 4-10  
    adding test drivers, 4-13  
    adding test equipment, 4-5  
    administration configuration, 4-5  
    configuration, 4-4  
    editing test equipment, 4-9  
    equipment, 4-2  
    installing, 4-3  
    removing datapacks, 4-20  
    removing device drivers, 4-13  
    removing test drivers, 4-16  
    removing test equipment, 4-8  
    running, 4-4  
    service, 4-1  
    user configuration, 4-5  
software, support, 5-5  
specifications, 1-1  
    amplitude modulation, 1-11  
    external modulation inputs, 1-14  
    frequency, 1-2  
    frequency modulation, 1-8  
    general, 1-16  
    internal modulation source, 1-13  
    internal reference oscillator, 1-4  
    LF out, 1-14  
    output, 1-4  
    phase modulation, 1-10  
    pulse modulation, 1-12  
    remote programming, 1-15  
    simultaneous modulation, 1-15  
    spectral purity, 1-7  
    sweep modes, 1-3  
spectral purity specifications, 1-7  
spectrum analyzer, 2-2  
spurious signals, 5-25  
standby symbol, 8-3  
statement of compliance, 8-5  
subharmonic spurious signals, 5-25  
supplemental characteristics, 1-1  
support software, 5-5  
    exiting, 5-10  
    sweep mode  
    specifications, 1-3

### T

test equipment, 5-4  
    list, 5-7  
test records, 5-3, 5-35, 5-36, 5-37  
    photocopying, 5-35  
test results  
    printing, 5-10

---

## Index

saving, 5-8  
timebase aging rate performance test,  
5-3

### U

universal counter, 2-3  
user information window, 5-5

### V

verifying operation, 3-1

### W

warning sign, 8-2  
warranty, 8-7  
waveform generator, 2-3  
window  
DUT, 5-6  
main test and results, 5-9  
save as, 5-8  
select test equipment and tests, 5-7  
user information, 5-5